

INTRODUCTION

Prof. Alina Karabchevsky, www.alinakarabchevsky.com

Integrated Photonics Course 377-2-5599

School of ECE

Ben-Gurion University of the Negev, Israel

1

SYLLABUS

Topic	Content	Lectures	References
Introduction	Course content and requirements, classification of waveguide platforms, comparison to electronics	1,	
Optical waveguide modes	Boundary conditions, modes propagation in slab waveguides, Helmholtz equation, cut-off condition for symmetric and anti-symmetric waveguides	2-4	1-3
Index control technologies	Changing free-carriers in semiconductors, isotropic vs anisotropic materials, electro-optic effect, electrooptic modulator, waveguide fabrication (epitaxial, diffused, laser induced)	5	1
Channel waveguides	Strip-loaded, ridge, rib, buried, diffused, applications, packaging	6	1-2
Simulation task submission	11 May 2026	7-8	
Losses in optical waveguides	Attenuation, scattering, absorption, thermal generation, optical generation, molar concentration, free-carriers absorption, radiation loss, detector on waveguide.	9	1
Composite plasmonic waveguides	Extended surface plasmon, localized surface plasmon, composite plasmonic waveguide	19	4-5
Students' lectures	8 and 15 June 2026	11-12	
Test בוחן	22 June 2026	13	

Grade composition: 30% Test (בוחן) + 30% Simulation + 20% Presentation + 20% Homework & participation

REFERENCES:

- 1) Karabchevsky, Alina, et al. "On-chip nanophotonics and future challenges." *Nanophotonics* 9.12 (2020): 3733-3753.
- 2) Hunsperger, R. G. (1995). *Integrated optics (Vol. 4)*. Berlin, Heidelberg: Springer Verlag.
- 3) Okamoto, K. (2021). *Fundamentals of optical waveguides*. Elsevier.
- 4) Novotny, L., & Hecht, B. (2012). *Principles of nano-optics*. Cambridge university press.
- 5) Enoch, S., & Bonod, N. (Eds.). (2012). *Plasmonics: from basics to advanced topics (Vol. 167)*. Springer.

SIMULATION TASK

Simulation task 30% demands:

- Use any numerical modelling tool. For instance COMSOL Multiphysics or Lumerical or CST and others have one month trial version.
- Check the Simulation task description in the course website.
- Upload your models, extracted fields and summarize Word document in shared drive folder.

Send to alinak@bgu.ac.il till 11 may 2026.

PRESENTATION TASK

Presentation 20% (one presentation) demands:

- Preparation: The frames will be prepared for professional presentation using *Beamer* frames written in the *LaTeX* code or ppt.
- Topic: One of the course topics (please coordinate with the Lecturer)
- Duration: The presentation will last at least 25 minutes.
- Points to consider: **Introduce the background on the topic**, then a) Literature overview to **introduce the topic** presented in the frames, b) detailed theoretical background, c) considerations for the **systems that can be designed** and comparison to similar devices, d) possible **future works**.
- Presentations dates: see first lecture

Topics:

- Coupling between Waveguides, Utilization of the deep learning in integrated photonics, Electro-Optic Modulators, Distributed-Feedback Lasers, Acousto-Optic Modulators, Optical Amplifiers on a chip, Integrated Optical Detectors, Photonic and Microwave Wireless Systems, Nanophotonics.

Please send the topic you wish to present to alinak@bgu.ac.il for approval till the second lecture of the course.

OUTLINE

Introduction

- History

Advantages of Integrated Optics

- Comparison of Optical Fibers with Other Interconnectors
- Comparison of Optical Integrated Circuits with Electrical Integrated Circuits

Substrate Materials for Optical Integrated Circuits

- Hybrid Versus Monolithic Approach
- III–V and II–VI Ternary Systems
- Hybrid OIC's in Lithium niobate (LiNbO_3)

Bibliography

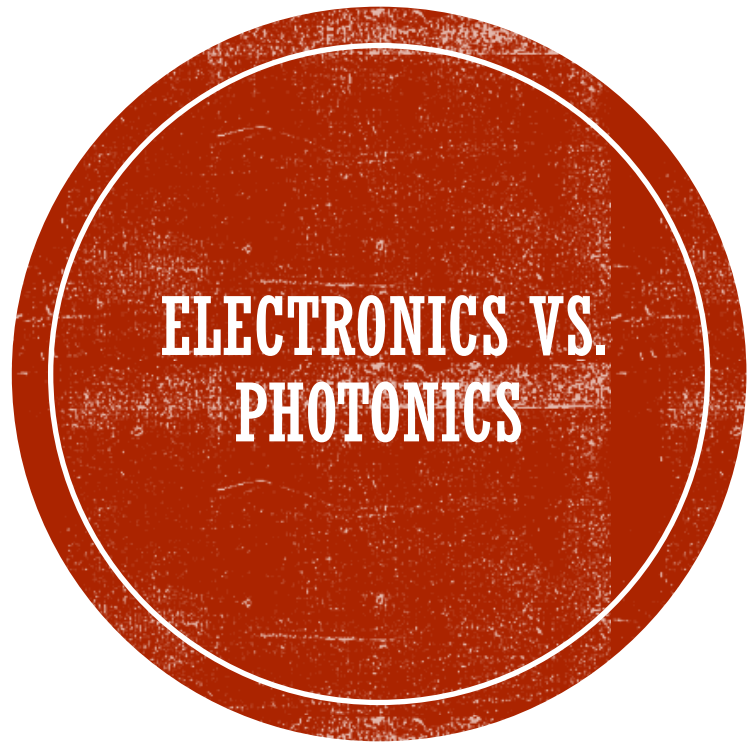

ELECTRONICS VS. PHOTONICS

Electronics:

The study of the flow of charge (electron) through various materials.

It involves the transmission of power and possibly information.

Photonics:

The technology of generating/controlling/detecting light and other forms of radiant energy.

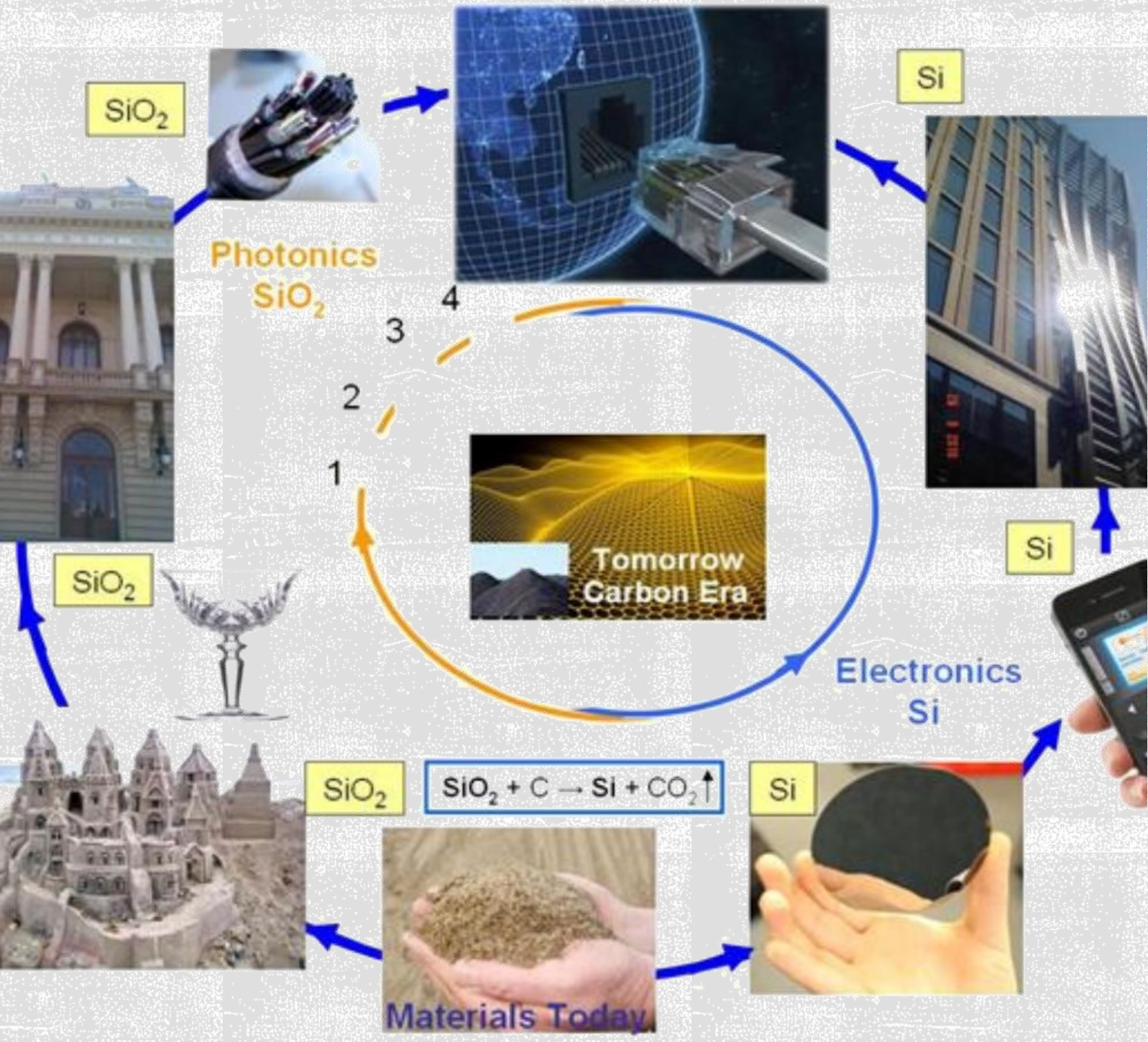

ELECTRONICS VS. PHOTONICS

Electronics:

The study of the flow of charge (electron) through various materials.

It involves the transmission of power and possibly information.

Photonics:

The technology of generating/controlling/detecting light and other forms of radiant energy.

INTRODUCTION

- The area of integrated optics has been concerned with a wide variety of phenomena involving light guided along and controlled by thin dielectric films or strips. The wavelengths of interest lie mostly between 0.4 and $10.0 \mu\text{m}$ ($4 \cdot 10^3 - 10^5 \text{ \AA}$), this range being determined primarily by available laser frequencies and by material properties.
- For wavelengths much larger than $10 \mu\text{m}$, i.e., in the millimeter region and beyond, metallic waveguiding techniques of the microwave variety have provided a more efficient technology. For wavelengths around $0.1 \mu\text{m}$ or smaller, the absence of suitable sources and the presence of large absorption and scattering losses impose limitations on the practical use of waveguiding effects.



HISTORICAL OVERVIEW

The **transmission** and processing of signals carried by optical beams rather than by electrical currents or radio waves has been a topic of great interest ever since **the early 1960s**, when the development of the laser first provided a stable source of coherent light for such applications.

Why are waveguides needed? Laser beams can be transmitted through the air, but atmospheric variations cause undesirable changes in the optical characteristics of the path from day to day, and even from instant to instant. Laser beams also can be manipulated for signal processing, but that requires optical components such as prisms, lenses, mirrors, electro-optic modulators and detectors. All of this equipment would typically occupy a laboratory bench tens of feet on a side, which must be suspended on a vibration-proof mount. Such a system is tolerable for laboratory experiments but is not very useful for practical applications.

HISTORICAL OVERVIEW

- In **the late 1960s**, the concept of "integrated optics" emerged, in which wires and radio links are replaced by light-waveguiding optical fibers rather than by through-the-air optical paths, and conventional electrical integrated circuits are replaced by miniaturized optical integrated circuits (OIC's), also known as photonic integrated circuits (PIC's).
- During the later years of **the 1970s**, several factors combined to bring integrated optics out of the laboratory and into the realm of practical application; these were the development of low loss optical fibers and connectors, the creation of reliable CW GaAlAs and GaInAsP laser diodes, and the realization of photolithographic microfabrication techniques capable of submicron linewidths.
- In **the 1980s**, optical fibers largely replaced metallic wires in telecommunications, and a number of manufacturers began production of optical integrated circuits for use in a variety of applications.

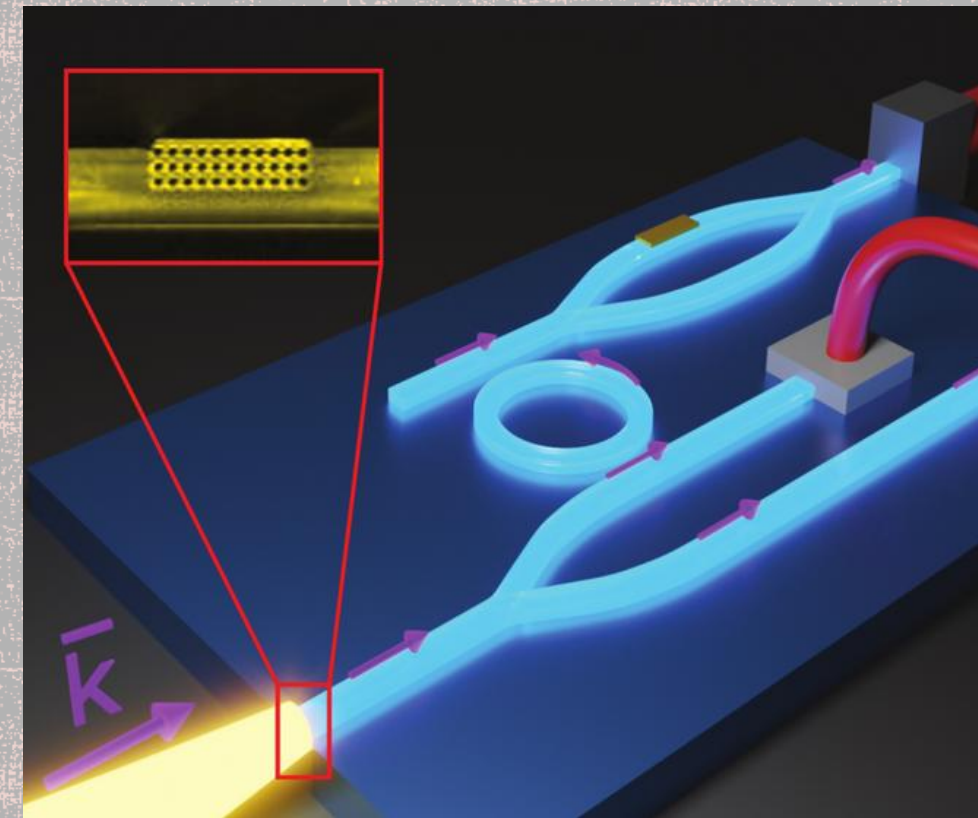

HISTORICAL OVERVIEW

- **In the 1990s**, the incorporation of optical fibers into telecommunications and data-transmission networks has been extended to the subscriber loop in many systems. This provides an enormous bandwidth for multichannel transmission of voice, video and data signals. Access to worldwide communications and data banks has been provided by computer networks such as the Internet. We are in the process of developing what some have called the "Information superhighway". The implementation of this technology has provided continuing impetus to the development of new integrated optic devices and systems into the beginning years of the 21st century.
- Another technological advance that has encouraged the development of new integrated optic devices in recent years is the availability of improved fabrication methods. Microtechnology, which involves dimensions on the order of micrometers, has evolved into nanotechnology, in which nanometer-sized features are routinely produced.

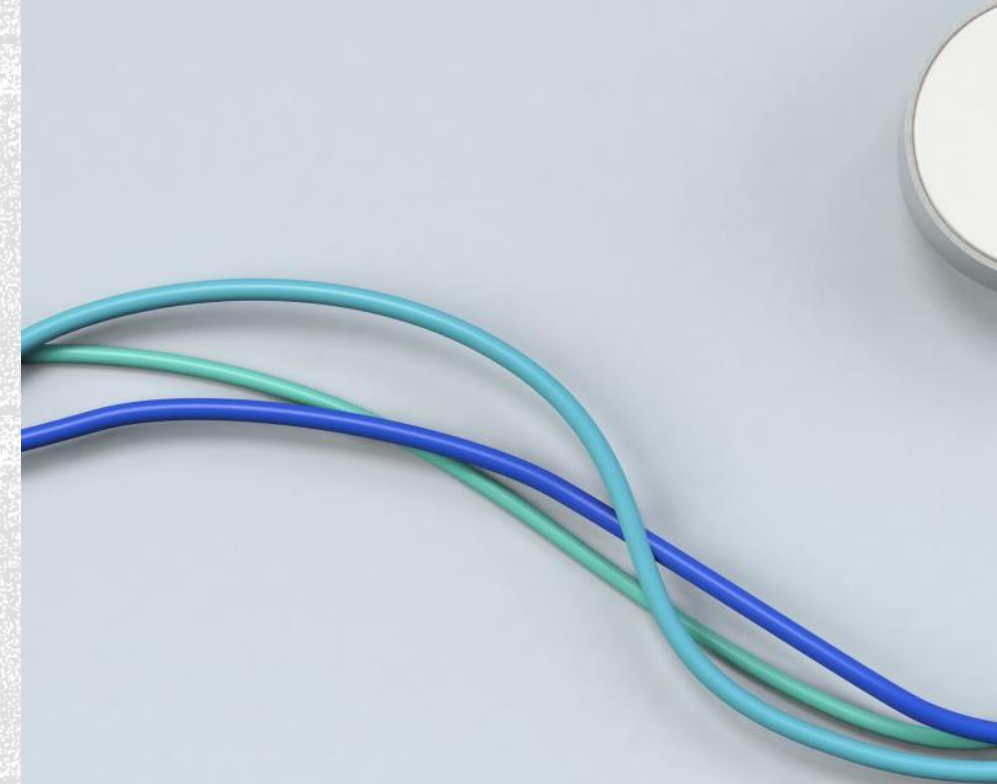

HISTORICAL OVERVIEW

The invention of the laser in 1961 and particularly the GaAs laser in 1962 led research workers in the telecommunication field to examine the possibilities of using light in place of electricity for signal transmission.



As **integrated optics** is based on the guiding of electromagnetic energy at optical frequencies by thin films, its origins have been stimulated and influenced mostly by two separate technical areas: microwave engineering and thin-films optics. A special role has also been played by semiconductors, which now appear to be most promising in promoting the goal of monolithic integrated optical circuits. If realized, these circuits would serve as miniature optical counterparts of microwave devices and networks, except that integrated optical circuits would offer the advantages of much **larger bandwidth and negligible sensitivity to interference by natural or man-made electromagnetic fields of lower frequencies.**

THE FIRST SIX YEARS OF IO

1962 - 1968 the inception of several studies of thin-film phenomena, have motivated by different goals and converged into laying the basis for much of what is considered today as belonging to the IO area.

The planar dielectric waveguides were well understood and used in microwave engineering [1] much before 1962.

In 1965, the microwave concepts were combined with photolithographic techniques to construct thin-film waveguides as well as other planar components and circuitry for applications in the infrared range by Anderson and his group [3,4] - "quasi-microwave optics" as newly developing technology.

Earlier in 1963, the guiding action of planar layers in p-n junctions had been observed and reported by Yariv and Leite [5], and Bond et al. [6].

THE FIRST SIX YEARS OF IO

- The results of Yariv and co. were subsequently employed by Nelson and Reindart [7] who showed that the planar guided modes in p-n junctions can provide the light modulation via the electro-optic effect.
- While the above studies were in progress, Osterberg and Smith [8] carried out experiments with glass sheets and prisms that, although not yet using laser light, nevertheless provided both optical guidance by planar films and coupling of a light beam into these films. In fact, as shown in Fig. 3, their experiment achieved image transmission by coupling through a prism L into a planar guide S_1 , which transferred the light towards a gap; some of this light crossed the gap through a slit U and then was partially captured by another similar glass sheet S_2 , from which optical energy was collected by a second prism R .



IMAGE-TRANSMISSION EXPERIMENT

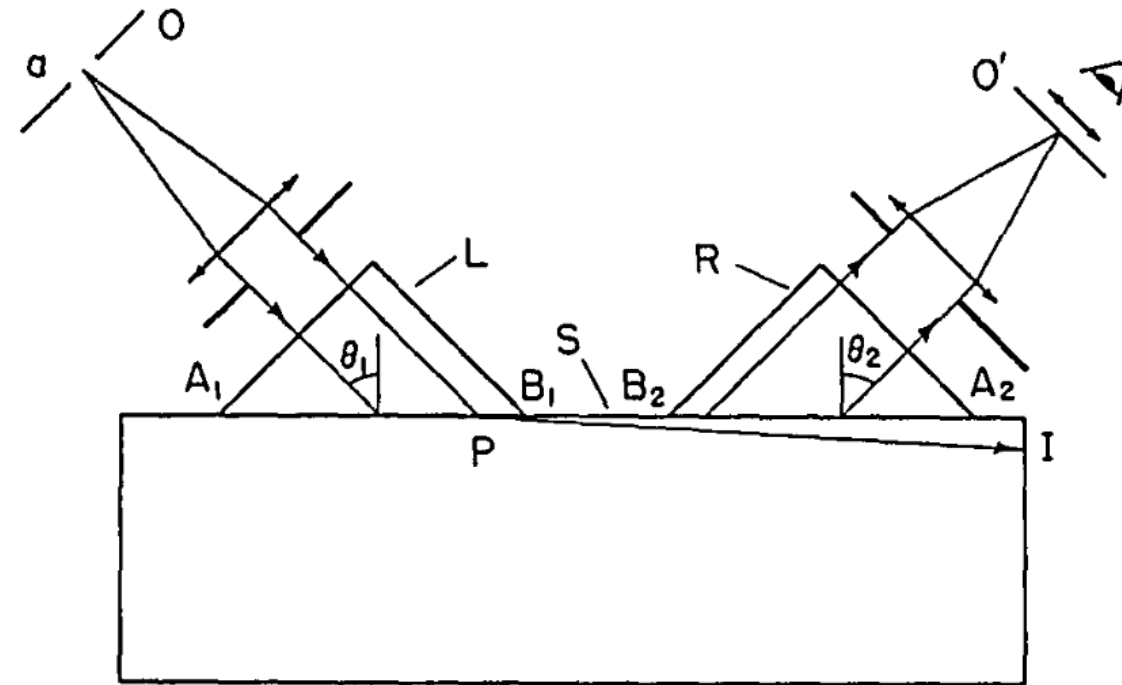

Figure 1: An arrangement for launching and receiving images by surface guided waves [8].

IMAGE-TRANSMISSION EXPERIMENT

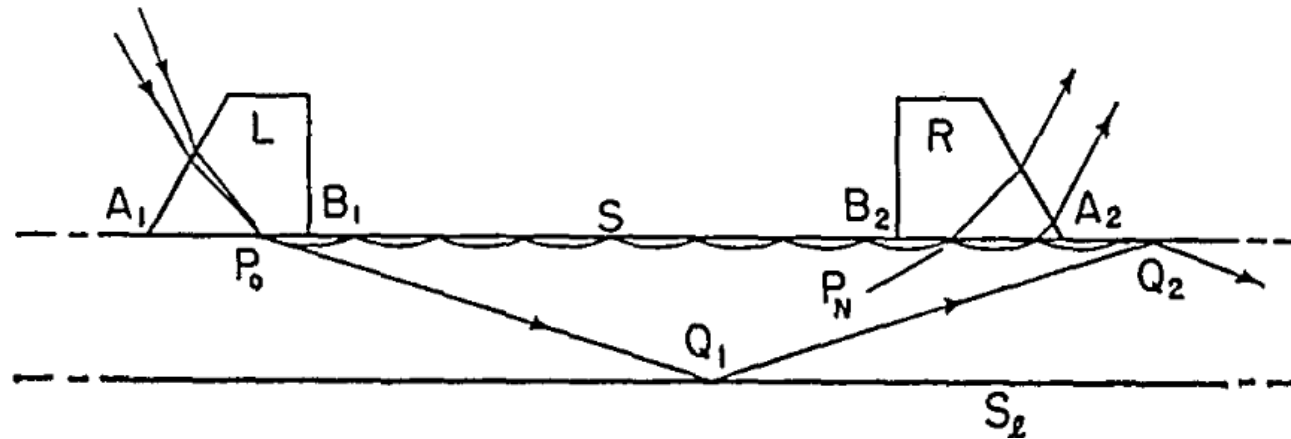

Figure 2: Illustration that prisms L and R must be spaced so as to avoid the directly reflected beam $Q_1 Q_2$ from the lower surface S_2 of thin plates [8].

IMAGE-TRANSMISSION EXPERIMENT

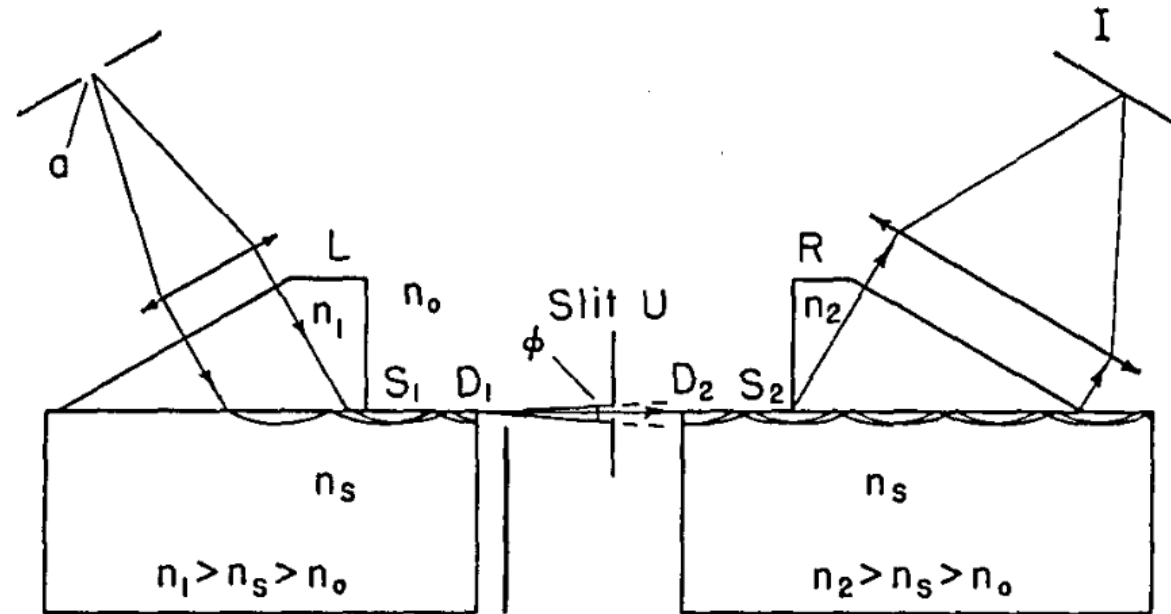

Figure 3: Illustration of energy transfer by an endfired beam between a launcher and a receiver [8].

IMAGE- TRANSMISSION EXPERIMENT

- This produced a beam that, when properly focused, reproduced at l the image of the input aperture a . The guiding along the glass surface was produced by the graded increase of the refractive index, which is particularly enhanced in Pilkington float glass. Viewed as an image transmission device, Osterberg and Smith's set-up can therefore be regarded as a first rudimentary implementation of a passive optical guided-wave apparatus, some elements of which are applicable even today.
- The above investigations, as well as the successful prior results on circular dielectric optical guides (or fibers) by Snitzer and Osterberg [9] and by Kapany and Burke [10], played a considerable role in arousing interest into planar optical guides.

IMAGE-TRANSMISSION EXPERIMENT

Although this concept is considered as a possible means for long-distance transmission [11], their fabrication [3,4,12,13] was motivated mostly by applications involving optical surface wave propagation over short distances only.

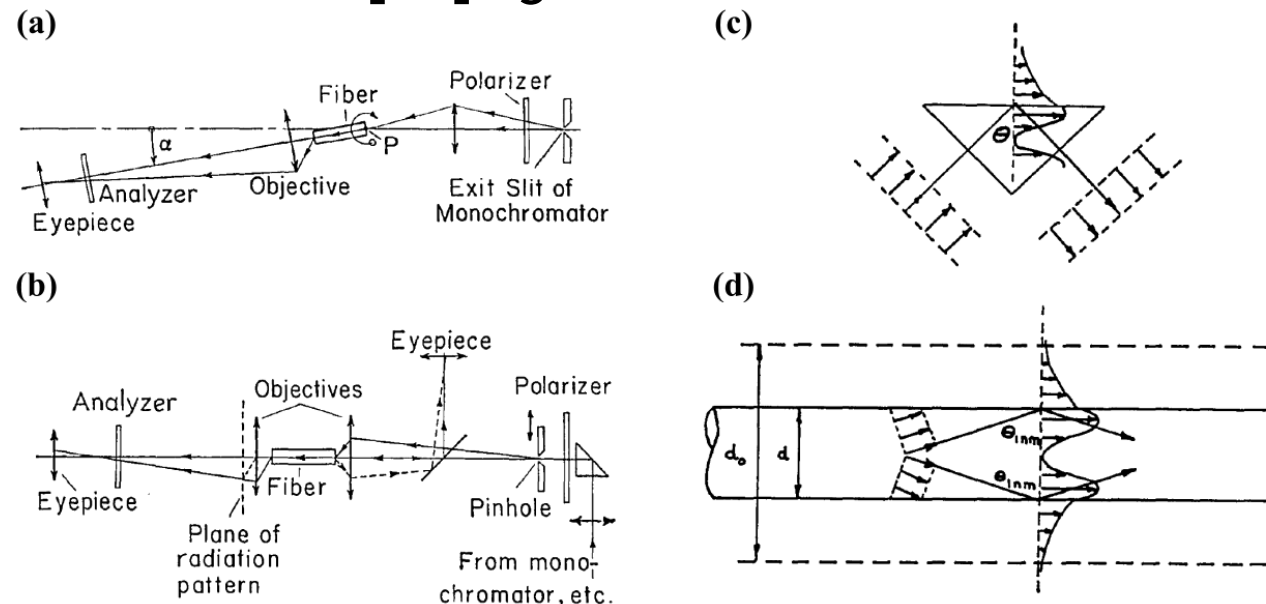

Figure 4: (a) Direct illumination and (b) pinhole illumination from [9]. Illustration of analogous interference and evanescent wave phenomena at (c) plane interface and (d) cylindrical fiber boundary [10].

THE TERMINOLOGY OF AN "INTEGRATED" - ALL OPTICAL PROCESSING

These applications suggested the use of optical surface waves in data-processing networks, so that terms such as "optical integrated data processors" [13] and "optical integrated circuits" [14] started being employed around 1968. In 1969, when abbreviating these expressions to "integrated optics". Miller [15] not only coined both an attractive and catchy name, but also heralded the beginning of vigorous efforts to investigate and develop a sound and reliable thin film technology for optical communications purposes.

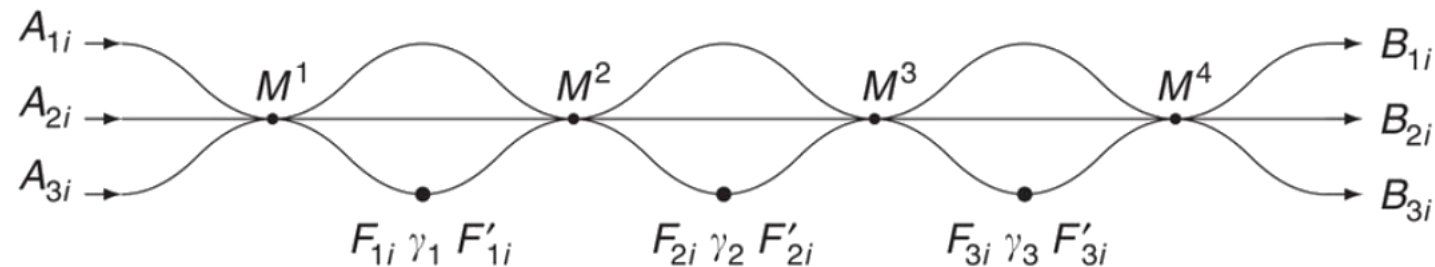

Figure 5: All-optical design for inherently energy-conserving reversible gates and circuits [16].

THE NEXT SIX YEARS

- The year 1968 brought great expectations on the potentialities of integrated optics and served as the start of a period of intense and fruitful activities, which stretch into the present. From the outset, it was projected by some that the ultimate goal of these activities would be to replace integrated-electronics circuits by equivalent, and possibly more effective, integrated-optics circuits.
- For this purpose, integrated-optics components must be **compact** and **miniature**, **reliable**, with **high mechanical and thermal stability**, **low power consumption** and preferably **integrable on a common substrate or chip**. These requirements stimulated the development of improved thin-film fabrication techniques and promoted numerous studies of new materials, for both passive and active functions.

WHAT HAVE BEEN ACHIEVED

Integrated Optics

Realizability demonstrated in lab and even commercially available.

Thin films

development of thin-film techniques and their application to the construction of passive and active devices.

Passive waveguides

improve the properties of planar waveguides and other passive components, such as directional couplers and transitions from one waveguide to another.

Losses

decrease the absorption and scattering losses. Losses lower than 1 dB/cm being obtainable by thin films of organic material, photoresist, sputtered glass and other suitable media.

Active components

counterpart of active devices, such as transistors, in integrated electronics. In integrated optics, these components include light sources, modulators and detectors.

ADVANTAGES OF A FIBER-OPTIC OIC SYSTEM

Figure below shows a hypothetical fiber-optic OIC system for optical communications that can be used to illustrate many of the special advantages of the integrated optic approach.

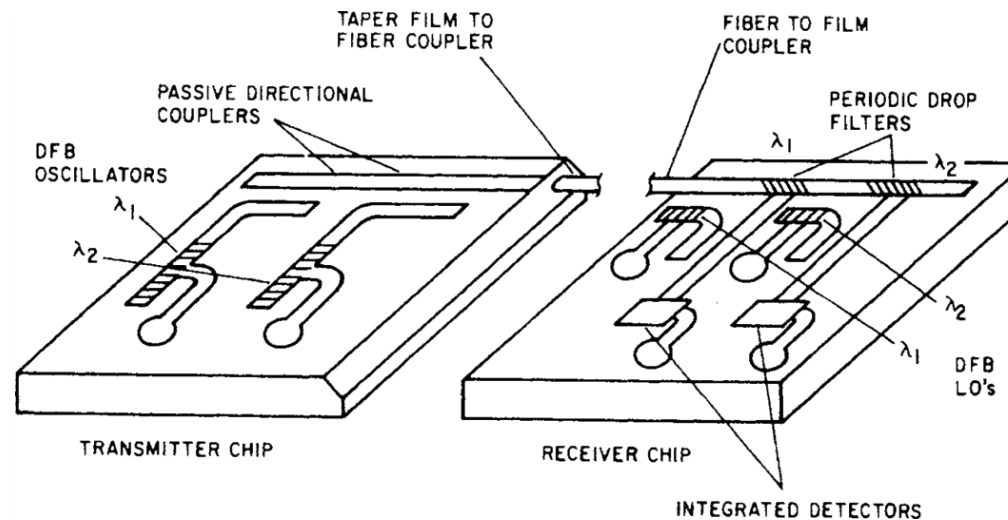

Figure 7: Monolithic integrated optic system for optical communications [17].

MONOLITHIC INTEGRATED TRANSMITTER

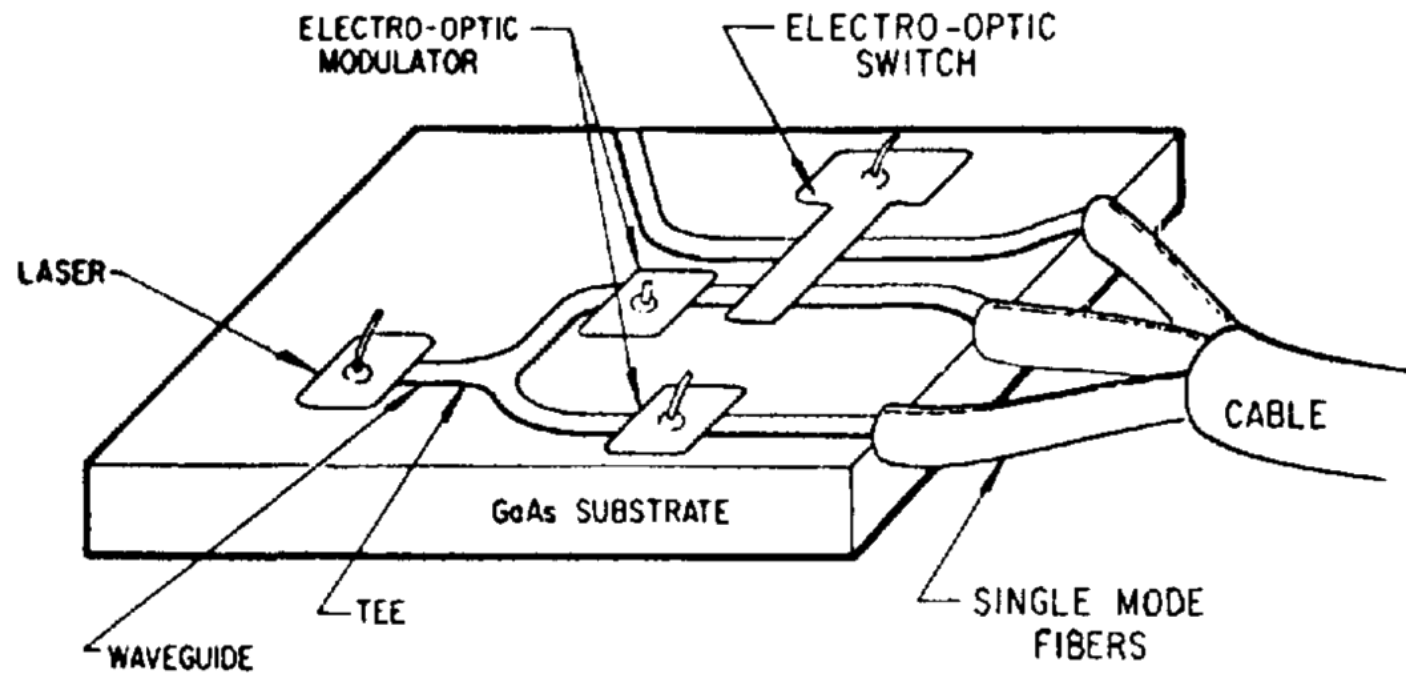

Figure 6: Schematics of a monolithic integrated GaAs transmitter.

MONOTONICALLY INTEGRATED OPTICAL SYSTEM

- In this system, the transmitter and receiver are each contained on an OIC chip, and the two are interconnected by means of an optical fiber waveguide.
- The light sources are integrated laser diodes of the distributed feedback (DFB) type, emitting at different wavelengths λ_1 , and λ_2 . Only two diodes are shown for simplicity. Since the light emitted by each laser is at a different wavelength, it travels via an essentially independent optical "carrier" wave within the waveguide, so that many signals can be transmitted simultaneously, or "multiplexed", by the optical fiber.
- In the receiver, these signals can be separated by wavelength selective filters and routed to different detectors. Additional laser diodes may be used in the receiver as local oscillators (LO) for heterodyne detection of the optical signals.

IO COMPARED TO IE

- **Single chip** the transmitter and receiver are each contained on an OIC chip, and the two are interconnected by means of an optical fiber waveguide.
- **Light sources** are integrated laser diodes of the distributed feedback (DFB) type, emitting at different wavelengths λ_1 and λ_2 .
- **Passive waveguides** improve the properties of planar waveguides and other passive components, such as directional couplers and transitions from one waveguide to another.
- **Losses** decrease the absorption and scattering losses. Losses lower than 1 dB/cm being obtainable by thin films of organic material, photoresist, sputtered glass and other suitable media.
- **Active components** counterpart of active devices, such as transistors, in integrated electronics. In integrated optics, these components include light sources, modulators and detectors.

COMPARATIVE EVALUATION OF OPTICAL INTERCONNECTORS

For many years, the standard means of interconnecting electrical subsystems, has been either the metallic wire or the radio link through the air. The optical fiber waveguide has many advantages over these conventional methods.

Advantages:

- Immunity from electromagnetic interference (EMI).
- Freedom from electrical short circuits or ground loops.
- Safety in combustible environment.
- Security from monitoring.
- Low-loss transmission.
- Large bandwidth (i.e., multiplexing capability).
- Small size, light weight.
- Inexpensive, composed of plentiful materials.

Major disadvantage

- Difficult to use for electrical power transmission.

COMPARATIVE EVALUATION OF OPTICAL INTERCONNECTORS

Metal wires:

- It can act as receiving antennas, in which extraneous signals are generated by induction from the electromagnetic fields that surround the wire.
- It can, of course, be shielded, as in the case of coaxial cables. The metallic shield adds weight, is costly, and produces parasitic capacitance that limits the frequency response or the bandwidth.

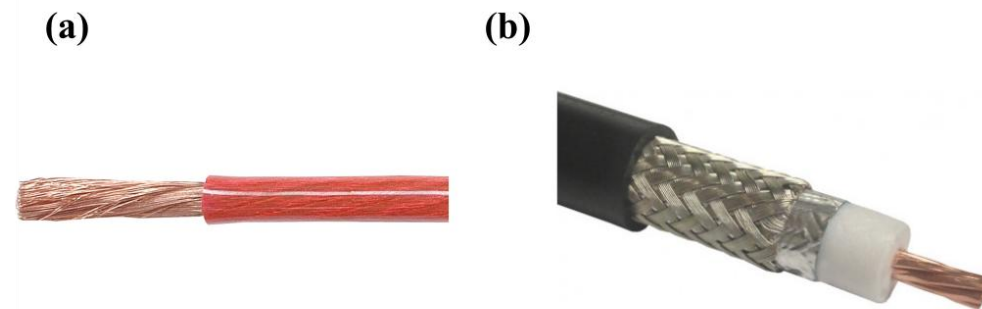
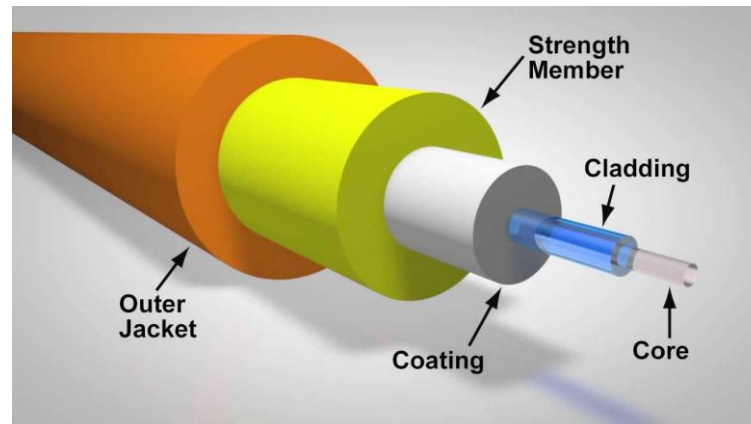

Figure 8: (a) American wire gauge (AWG) cable. (b) Coaxial cable.

COMPARATIVE EVALUATION OF OPTICAL INTERCONNECTORS

Optical fibers:

- It has inherent immunity to most forms of electromagnetic interference (EMI), since there is no metallic wire present in which current can be induced by stray electromagnetic coupling.
- Optical fibers do not allow flow of electrical current, so that electrical short circuits cannot occur. Thus, optical fibers can be bound into a tight bundle and can be routed through metallic conduits without concern for electrical insulation.



COMPARATIVE EVALUATION OF OPTICAL INTERCONNECTORS

Perhaps the most important advantage of fibers is that they can be used for low loss transmission of optical signals over 100 kilometer-length paths with bandwidths greater than 40 Gigabit/s, without optical amplifiers.

An overall transmission rate of 1800 Gb/s has been achieved by the use of dense wavelength division multiplexing (DWDM) and erbium-doped fiber amplifiers (EDFA) to transmit 180 10 Gb/s channels over 7000 km.

The loss can be reduced to less than 2 dB/km, even in relatively inexpensive, multimode, commercially available fibers. In single-mode fibers attenuation of less than 0.2 dB/km is common.

COMPARISON OF ATTENUATION

The losses in fibers are relatively independent of frequency, while those of competitive interconnectors increase rapidly with increasing frequency.

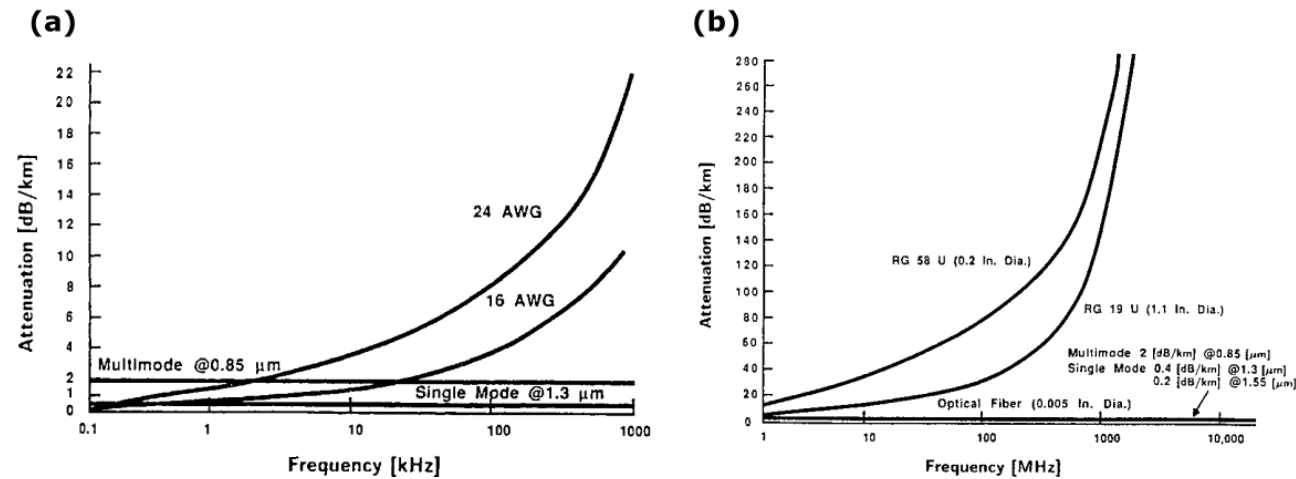

Figure 9: (a) Comparison of attenuation in optical fiber with that in twisted-pair cable (American Wire Gauge). (b) Comparison of attenuation in optical fiber with that in coaxial cable. [17]

COMPARATIVE EVALUATION OF OPTICAL INTERCONNECTORS

- For example, the data shown in Fig. 9a indicate losses in twisted-pair cable, which is commonly used as an interconnector in avionic systems, increase substantially at modulation frequencies above about 100 kHz.
- Coaxial cables are useful for transmission over relatively short paths, at frequencies up to about 100 MHz, even though losses are large, but above that frequency losses become excessive, as shown in Fig. 9b.
- By comparison, attenuation in fibers is insignificant even at frequencies up to 10 GHz. The maximum frequency at which fibers can be used to transmit a signal is limited not by attenuation, per se, but rather indirectly by the phenomenon of **dispersion**.

COMPARATIVE EVALUATION OF OPTICAL INTERCONNECTORS

Modal dispersion can be avoided, of course, by using a single-mode fiber, in which the core diameter is made very small ($< 10 \mu\text{m}$ for visible or near infrared wavelength) to cut off propagation of the higher-order modes. In that case, the bandwidth is limited only by the **material dispersion**. Single-mode fibers are relatively expensive compared to the multimode type and coupling and splicing problems are greatly aggravated by the small core diameter.

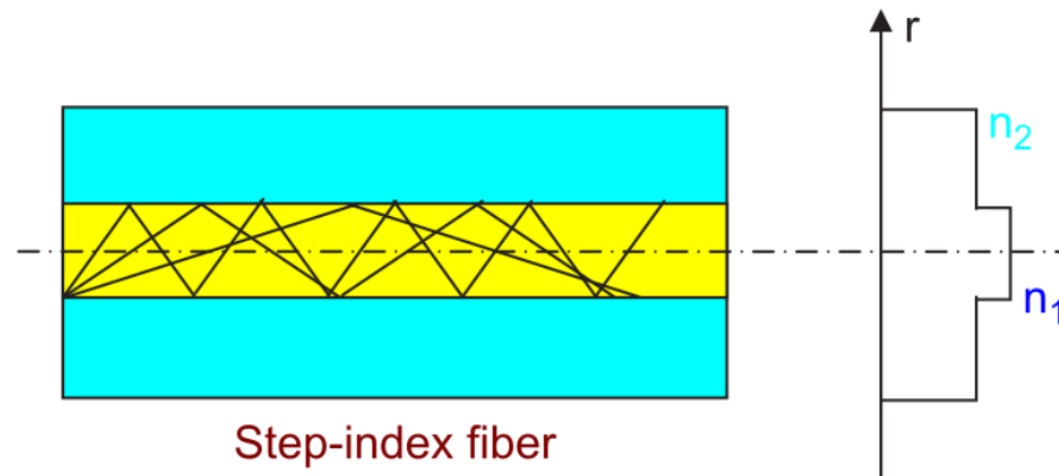

GRADED-INDEX FIBER

- An alternative approach is to use a graded index multimode fiber in which the refractive index of the core is graded from a maximum on axis to a minimum at the interface with the cladding. This grading of the index tends to equalize the effects of modal dispersion.
- Longer ray trace will pass in lower index and short ray trace in higher index. Therefore, longer ray trace will have in shorter optical path distance and short ray trace will have in longer optical path distance.

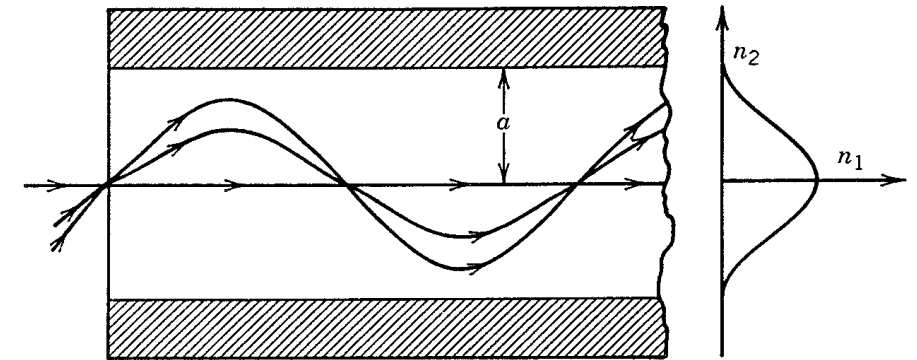

Figure 10: Ray trajectories in a graded-index fiber [18].

ELECTROMAGNETIC SPECTRUM

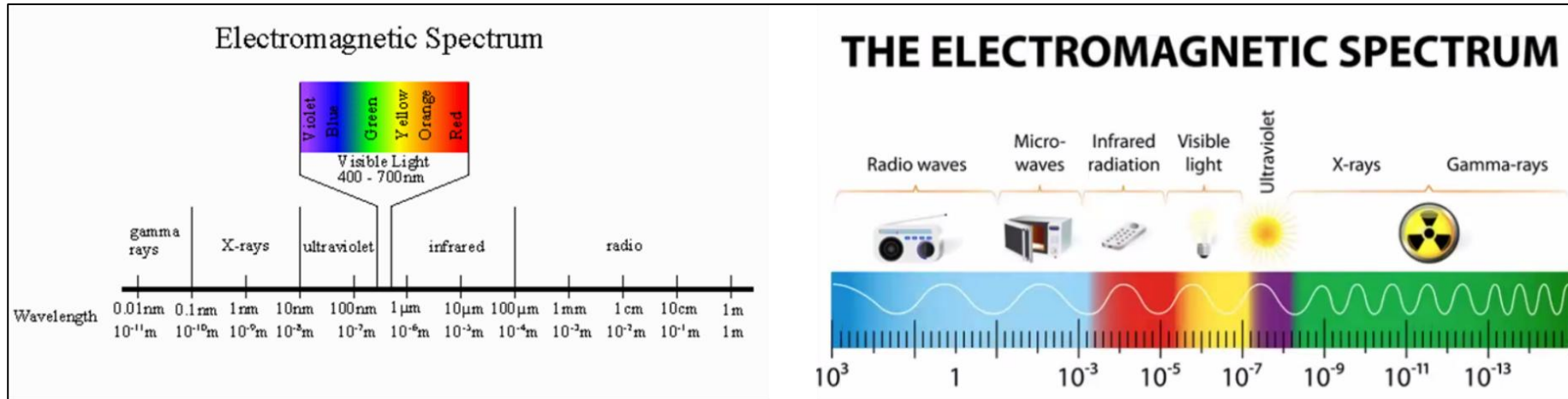

Figure 11: For optics communication we will focus on 1.3 μm and 1.55 μm .

ATTENUATION OF SILICA: ABSORPTION BY MOLECULAR VIBRATIONS OH OVERTONES

For optics communication we will focus in 1.3 μm and 1.55 μm .

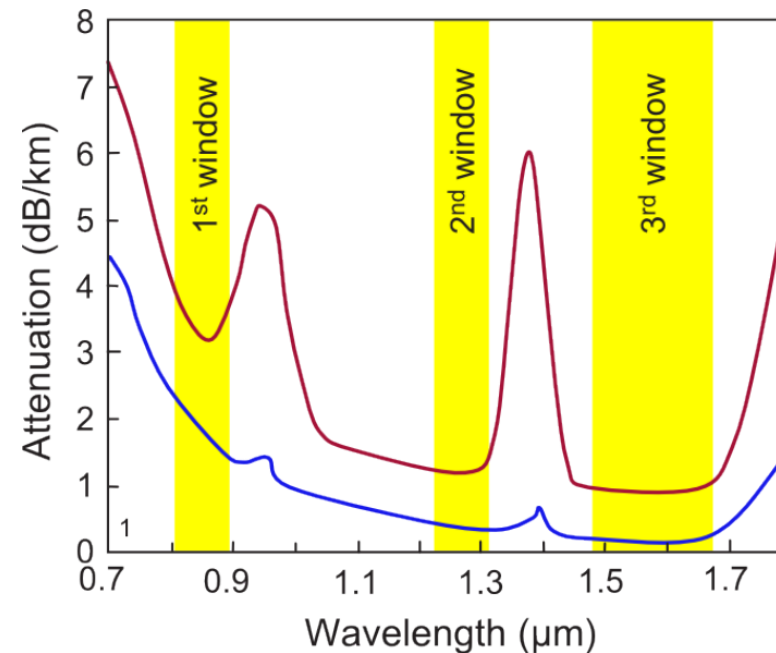

Figure 12: Attenuation of silica.

COMPARISON OF OPTICAL INTEGRATED CIRCUITS WITH ELECTRICAL INTEGRATED CIRCUITS

Advantages:

- Increased bandwidth.
- Expanded frequency (wavelength) division multiplexing.
- Low-loss couplers, including bus access types.
- Expanded multipole switching (number of poles, switching speed).
- Smaller size, weight, lower power consumption.
- Batch fabrication economy.
- Improved reliability.
- Improved optical alignment, immunity to vibration.

Major disadvantage

- High cost of developing new fabrication technology.

COMPARISON OF OPTICAL INTEGRATED CIRCUITS WITH ELECTRICAL INTEGRATED CIRCUITS

In addition to facilitating the coupling of many signals onto a waveguide, the optical integrated circuit also lends itself to convenient switching of signals from one waveguide to another.

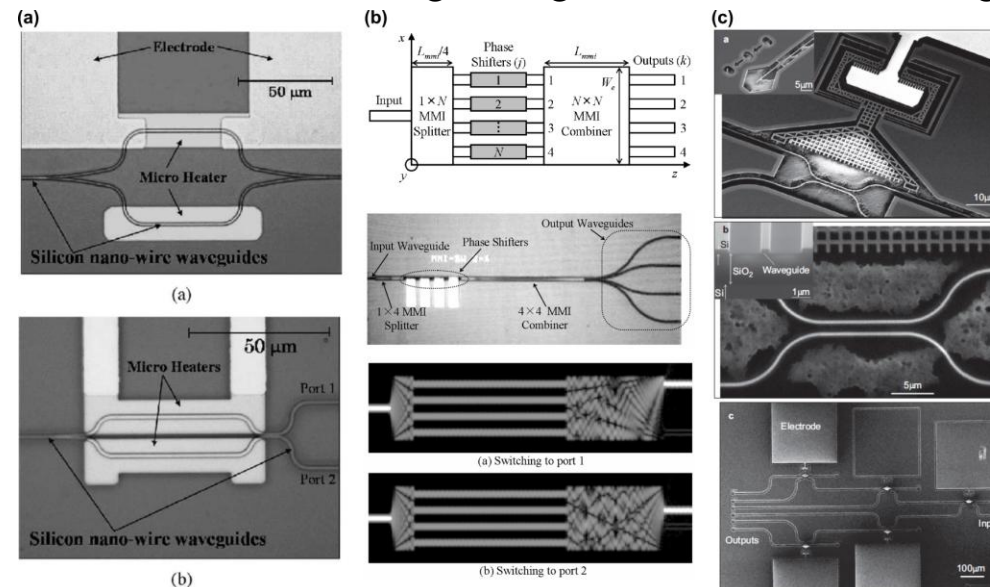
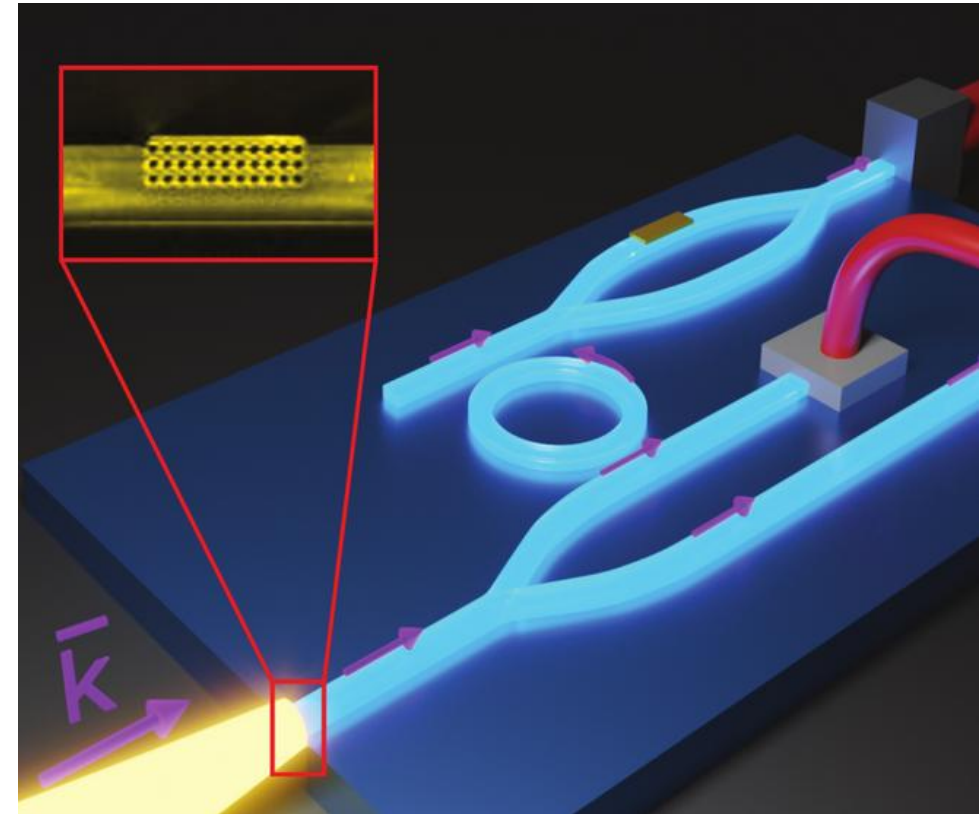

Figure 13: (a) Thermo-optic switch based on the Si photonic wire waveguides of 1x1 switch and 1x2 switch [19]. (b) Dynamic switching of 1x4 InGaAsP/InP MMI waveguide switch [20]. (c) silicon nanowire waveguide 2x6 multiple switch [21].

COMPARISON OF OPTICAL INTEGRATED CIRCUITS WITH ELECTRICAL INTEGRATED CIRCUITS

- When compared to larger, discrete component optical systems, OIC's can be expected to have the same advantages that electrical integrated circuits enjoy over hand-wired discrete component circuits. These include smaller size, weight and lower power requirements, as well as improved reliability and batch fabrication economy.
- In addition, optical alignment and vibration sensitivity, which are difficult problems in discrete component optical systems, are conveniently controlled in the OIC.



Falek, E., Katiyi, A., Greenberg, Y., **Karabchevsky, A.** 2021. On-Chip Metasurface-on-Facets for Ultra-High Transmission through Waveguides in Near-Infrared. [Advanced Optical Materials](#), 9(11), (2100130) 1-8.

SUBSTRATE MATERIALS FOR OPTICAL INTEGRATED CIRCUITS

- The choice of a substrate material on which to fabricate an optical integrated circuit depends most strongly on the function to be performed by the circuit.
- In most cases, the OIC may consist of several different optical devices such as sources, modulators, and detectors, and no one substrate material will be optimum for all of them.
- Thus, a compromise must be made. The first step is to decide whether a hybrid or a monolithic approach is preferred.

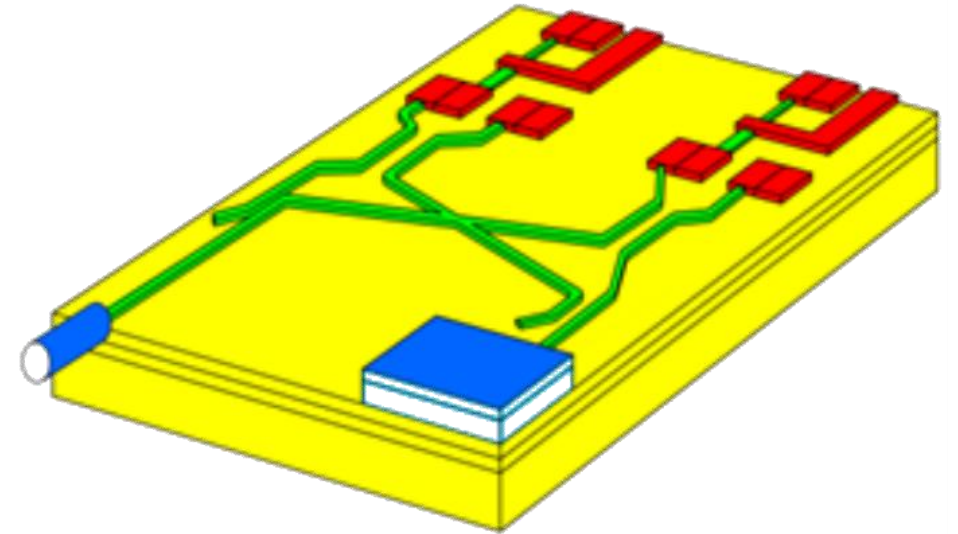

HYBRID VERSUS MONOLITHIC APPROACH

There are two basic forms of optical integrated circuits:

- **hybrid OIC** in which two or more substrate materials are somehow bonded together to optimize performance for different devices.
- **monolithic OIC** a single substrate material is used for all devices.

Since most OIC's will require a source of light, monolithic circuits can only be fabricated in optically active materials, such as the semiconductors. Passive materials like quartz, lithium niobate or polymers are also useful as substrate materials but generally an external light source, such as a semiconductor laser, must somehow be optically and mechanically coupled to the substrate. However, in recent years significant progress has been made in producing light emitters and amplifiers by incorporating erbium and other atoms ions into passive substrate materials such as glasses and polymers.

MONOLITHIC INTEGRATION

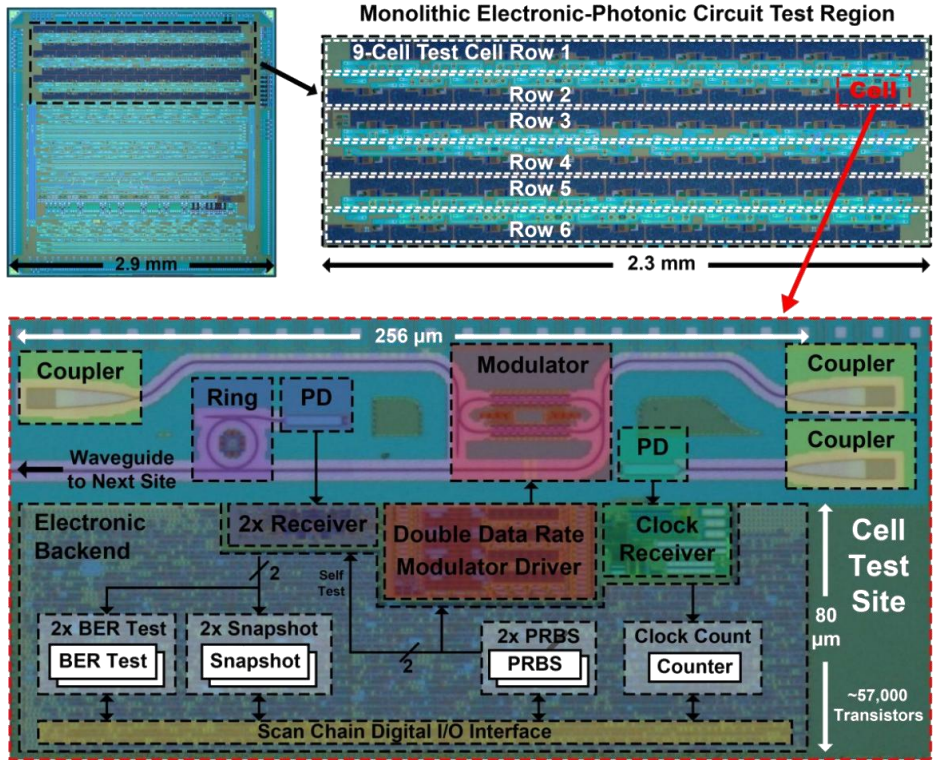

Figure 14: Illustrated micrograph of the fabricated electronic-photonic integration [22].

MONOLITHIC INTEGRATION

The digital Fourier transform (dFT) spectrometer comprises of a reconfigurable Mach-Zehnder interferometers (MZI), which is schematically illustrated in the Figure below.

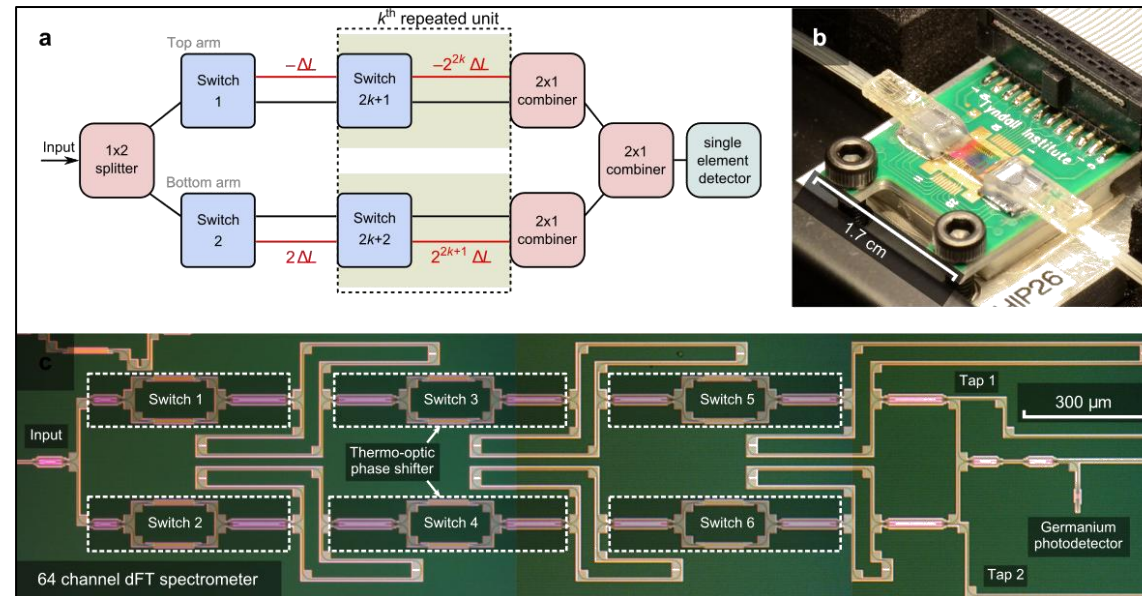

Figure 15: Images and schematics of the dFT architecture [23].

MULTI-CHIP INTEGRATION

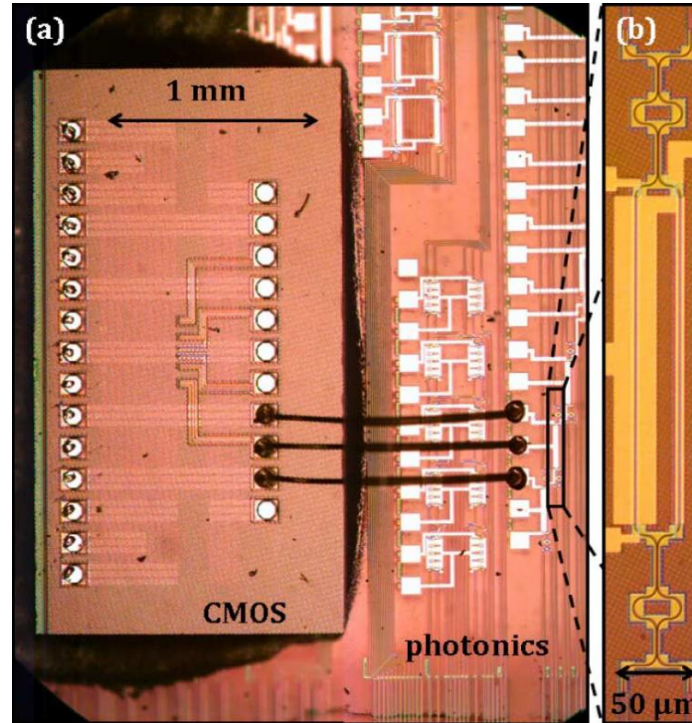

Figure 16: (a) Image of the wire-bond-integrated CMOS and photonic chips. (b) Magnified view of the WIMZ photonic switch [24].

MATERIALS FOR IO

Table 1: Materials for optical integrated circuits.

Passive (Incapable of light generation)	Active (Capable of light generation)
Quartz	GaAs
Lithium niobate	GaAlAs
Lithium tantalate	GaAsP
Tantalum pentoxide	GaInAs
Niobium pentoxide	other III-V, II-VI semiconductors
Silicon	Indium Phosphate
Polymers	
Silicon nitride	

HYBRID OIC

- The major advantage of the hybrid approach is that the OIC can be fabricated using existing technology, piecing together devices which have been substantially optimized in a given material. For example, one of the earliest OIC's to perform a complex system function was the RF spectrum analyzer, which combined a commercially available GaAlAs diode laser and a silicon photodiode detector array with an acousto-optic modulator on a lithium niobate substrate.
- A hybrid buttcoupling approach was used to efficiently couple both the laser diode and the detector array to the LiNbO_3 substrate. In this case, the hybrid approach made possible the combining of already well-developed technologies for GaAlAs heterojunction lasers LiNbO_3 acousto-optic waveguide modulators and Si photodiode arrays.

III–V AND II–VI TERNARY SYSTEMS

- Most monolithic OIC's can be fabricated only in active substrates, in which light emitters can be formed. This essentially limits the choice of materials to semiconductors, such as those listed in Table 1.
- The III-V (or II-VI) ternary or quaternary compounds are particularly useful because the energy bandgap of the material can be changed over a wide range by altering the relative concentrations of elements. This feature is very important to the solution of one of the basic problems of monolithic OIC fabrication.
- Semiconductors characteristically emit light at a wavelength corresponding approximately to their bandgap energy. They also very strongly absorb light having a wavelength less than, or equal to, their bandgap wavelength. Thus, if a light emitter, waveguide, and detector are all fabricated in a single semiconductor substrate such as GaAs, light from the emitter will be excessively absorbed in the waveguide but not absorbed strongly enough in the detector.

III-V AND II-VI TERNARY SYSTEMS

- So far, most of the research in monolithic OIC's has used the gallium aluminum arsenide, $\text{Ga}_{(1-x)}\text{Al}_x\text{As}$, system or the gallium indium arsenide phosphide, $\text{Ga}_x\text{In}_{(1-x)}\text{As}_{(1-y)}\text{P}_y$, system. These materials, often designated by the abbreviated formulae GaAlAs and GaInAsP, have several properties that make them especially useful for OIC fabrication.
- The most important of these have been enumerated in Table 2. By changing the fractional atomic concentration of the constituents, the emitted wavelength can be varied from 0.65 μm (for AlAs) to 1.7 μm (for GaInAsP). GaAlAs and GaInAsP also have relatively large electro-optic and acousto-optic figures of merit, making them useful for optical switch and modulator fabrication.

PROPERTIES OF GALLIUM ARSENIDE, GALLIUM ALUMINUM ARSENIDE, GALLIUM ALUMINUM ARSENIDE PHOSPHIDE

Table 2: Properties of GaAs, GaAlAs and GaInAsP useful in optical integrated circuits.

Transparency	0.6-12 μm
Emitted wavelength	0.65-1.7 μm
Lattice matching	Negligible lattice mismatch results in minimal strain
Switching	Large electro-optic and acousto-optic figures of merit $n_0^3 r_{41} \simeq 6 \times 10^{-11} \text{ m/V}$ $M \simeq 6 \times 10^{-13} \text{ s}^3/\text{kg}$
Technology	Epitaxy, doping, ohmic, contacts, masking, etching all are well developed
Cost	Less than other III-V or II-VI materials

GALLIUM ALUMINUM ARSENIDE

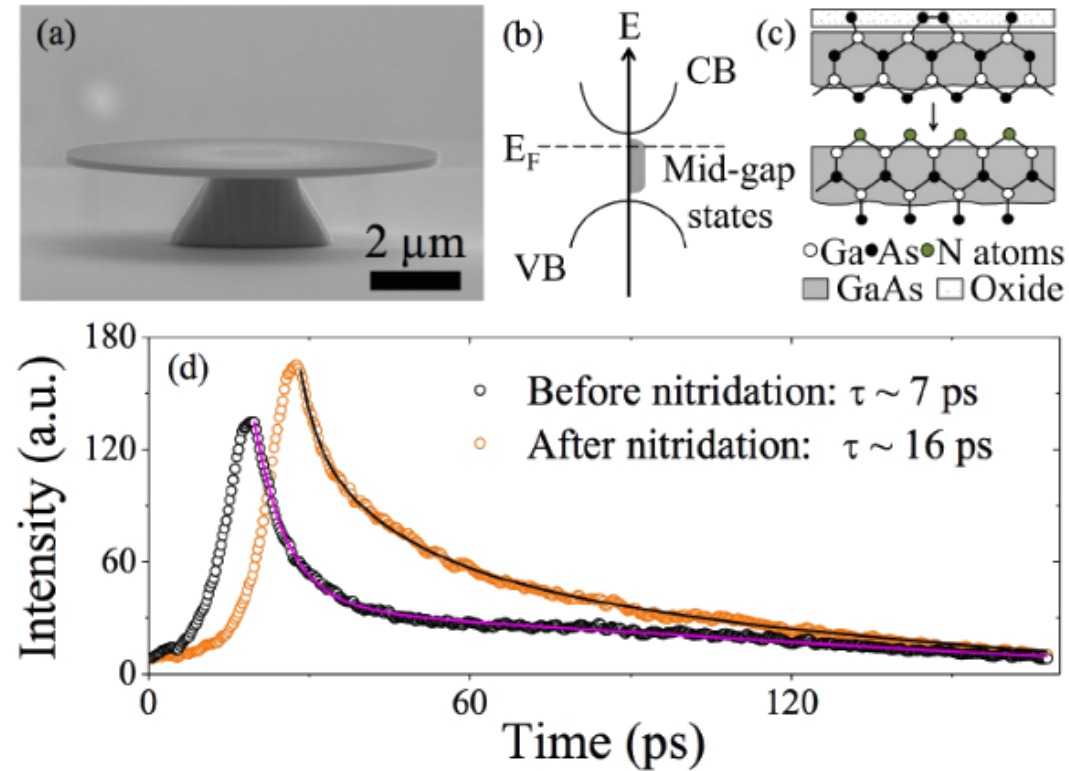
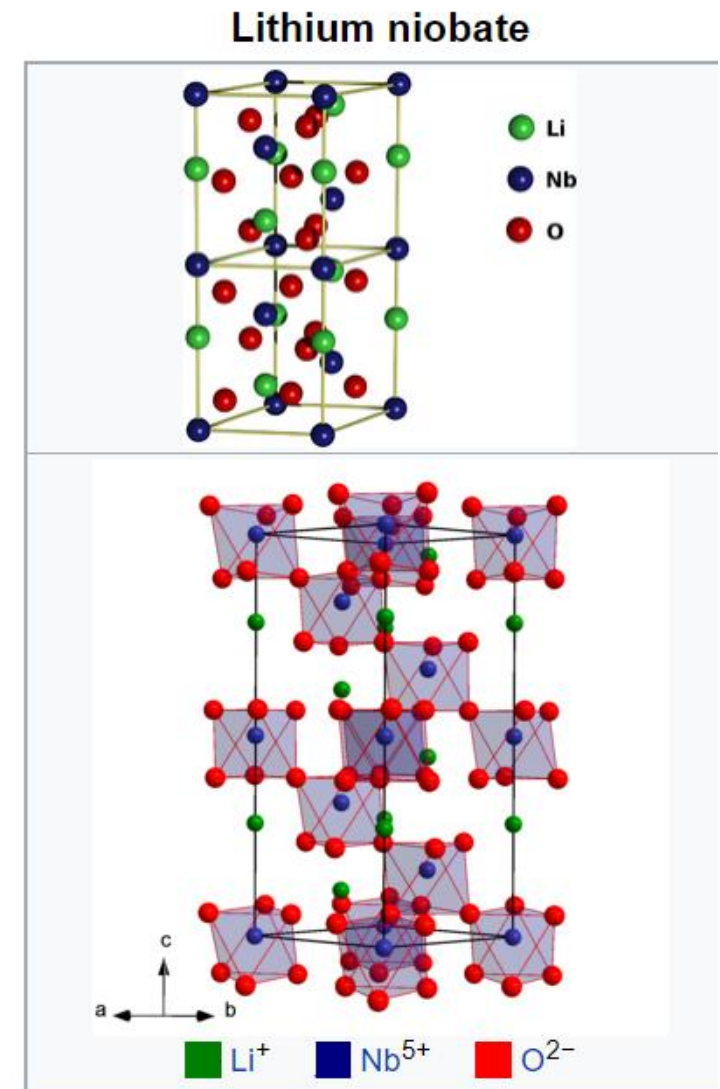

Figure 17: Wet nitridation of GaAs disk resonators.

PROPERTIES OF LITHIUM NIOBATE (LiNbO_3)

By contrast, hybrid OIC's fabricated in LiNbO_3 are presently commercially available from several different suppliers. These are relatively simple, including electro-optic modulators, Mach-Zehnder interferometric modulators, electro-optic switches and optical amplifiers. These OIC's take advantage of the wide wavelength range of transparency and large electrooptic coefficient of LiNbO_3 , as well as some other beneficial properties of that material.



PROPERTIES OF LITHIUM NIOBATE (LiNbO₃)

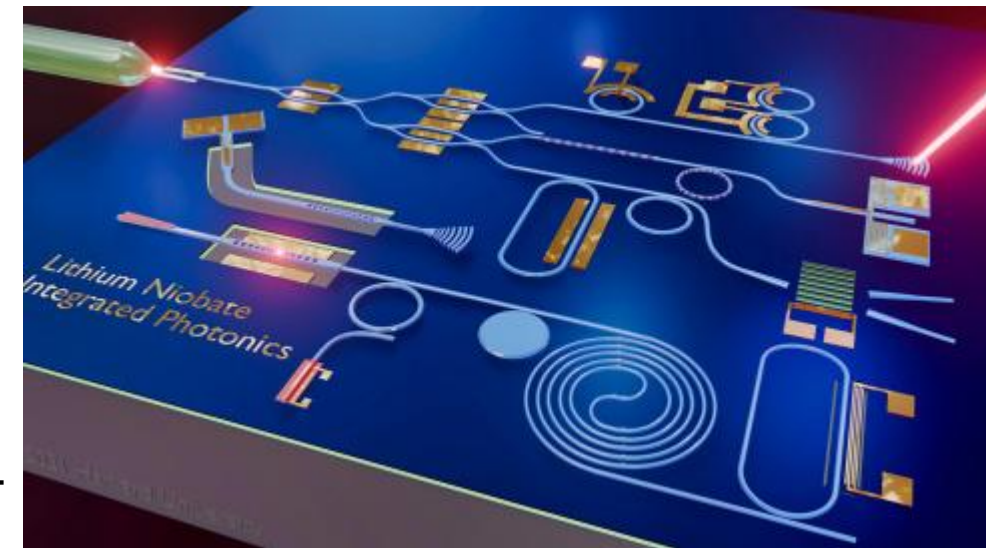

Table 3: Properties of LiNbO₃ useful in optical integrated circuits.

Transparency	0.2-12 μm
Emitted wavelength	none
Switching	Large electro-optic and acousto-optic figures of merit $n_0^3 r_{41} \simeq 3 \times 10^{-10} \text{ m/V}$ $M \simeq 6 \times 10^{-15} \text{ s}^3/\text{kg}$
Technology	Waveguide fabrication, masking, etching, polishing all are well developed
Cost	More than GaAs

BIBLIOGRAPHY I

- [1] N.S. Kapany and J.J. Burke, *Optical Waveguides* (Academic Press, New York, London, 1972), pp. 1-6.
- [2] D. Hondros and P. Debye, "Elektromagnetische wellen an dielektrischen drahten", *Annalen der Physik*, 337(8), (1910).
- [3] D.B. Anderson, "Application of semiconductor technology to coherent optical transducers and spatial filters". In *Optical and Electro-Optical Information Processing*, ed. by J. TIPPETT (M.I.T. Press, Cambridge, Mass., 1965), pp. 221-234.
- [4] D.B. Anderson and R. R. August, "Applications of microphotolithography to millimeter and infrared devices", *Proc. IEEE*, 54(4), (1966).
- [5] A. Yariv and R.C.C. Leite, "Dielectric-Waveguide Mode of Light Propagation in p-n Junctions", *Applied Physics Letters*, 2(3), (1963).
- [6] W.L. Bond, et al., "Observation of the Dielectric-Waveguide Mode of Light Propagation in p-n Junctions", *Applied Physics Letters*, 2(3), (1963).
- [7] D.F. Nelson and F.K. Reinhart, "Light Modulation by the Electro-Optic Effect in Reverse-Biased GaP p-n Junctions", *Applied Physics Letters*, 5(7), (1964).

BIBLIOGRAPHY II

- [8] H. Osterberg and L.W. Smith, "Transmission of optical energy along surfaces: Part I, homogeneous media", JOSA, 54(9), (1964).
- [9] E. Snitzer and H. Osterberg, "Observed dielectric waveguide modes in the visible spectrum", JOSA, 51(5), (1961).
- [10] N. S. Kapany and J.J. Burke, "Fiber optics. IX. Waveguide effects", JOSA, 51(10), (1961).
- [11] A.E. KAR OWIAK, "Optical waveguides", in Advances in Microwaves (Academic Press, New York, 1966), pp. 75-113.
- [12] E.R. Schineller, P.F. Richard and W.W. Donald, "Optical waveguides formed by proton irradiation of fused silica", JOSA 58(9), (1968).
- [13] R. Shubert and J.H. Harris, "Optical surface waves on thin films and their application to integrated data processors", IEEE Transactions on microwave theory and techniques, 16(12), (1968).
- [14] D.B. Anderson, "An integrated circuit approach to optical waveguide", Digest Abstract IEEE Microelectronics Symposium, St. Louis, Miss. (1968).

BIBLIOGRAPHY III

- [15] E. Marcatili, and S.E. Miller, "Improved relations describing directional control in electromagnetic wave guidance", Bell System Technical Journal, 48(7), (1969).
- [16] Cohen, E., Dolev, S., & Rosenblit, M. (2016). All-optical design for inherently energy-conserving reversible gates and circuits. Nature communications, 7(1), 11424.
- [17] Hunsperger, R. G. (1995). Integrated optics (Vol. 4). Berlin, Heidelberg: Springer Verlag.
- [18] Agrawal, G. P. (2012). Fiber-optic communication systems. John Wiley & Sons.
- [19] Hirohito Yamada, Tao Chu, Satomi Ishida, and Yasuhiko Arakawa. Si photonic wire waveguide devices. IEEE Journal of selected topics in quantum electronics, 12(6):1371–1379, 2007.
- [20] Shinji Tomofuji, Shinji Matsuo, Takaaki Kakitsuka, and Ken-ichi Kitayama. Dynamic switching characteristics of ingaasp/inp multimode interference optical waveguide switch. Optics express, 17(26):23380–23388, 2009.
- [21] Yuta Akihama and Kazuhiro Hane. Single and multiple optical switches that use freestanding silicon nanowire waveguide couplers. Light: Science & Applications, 1(6):e16-e16, 2012.

BIBLIOGRAPHY IV

- [22] J. Orcutt, B. Moss, C. Sun, et al., “Open foundry platform for high-performance electronicphonic integration”, Optics Express, 20 (2012).
- [23] Kita, Derek M., et al., ”High-performance and scalable on-chip digital Fourier transform spectroscopy.” Nature communications, 9(1), (2018).
- [24] B. Lee, C. Schow, A. Rylyakov, et al., “Demonstration of a digital CMOS driver codesigned and integrated with a broadband silicon photonic switch”, Journal of Lightwave Technology, 29, (2011).