

INDEX CONTROL TECHNOLOGIES

Prof. Alina Karabchevsky, www.alinakarabchevsky.com

Integrated Photonics Course 377-2-5599

School of ECE

Ben-Gurion University of the Negev, Israel

1

OUTLINE

Index control methods

- Changing the free carriers in semiconductor
- Isotropic and anisotropic materials
- The electro-optic effect
- Electro-optic modulator

Waveguides fabrication

- Epitaxial growth
- Thin layer growth
- Laser induced index control
- Diffused waveguide

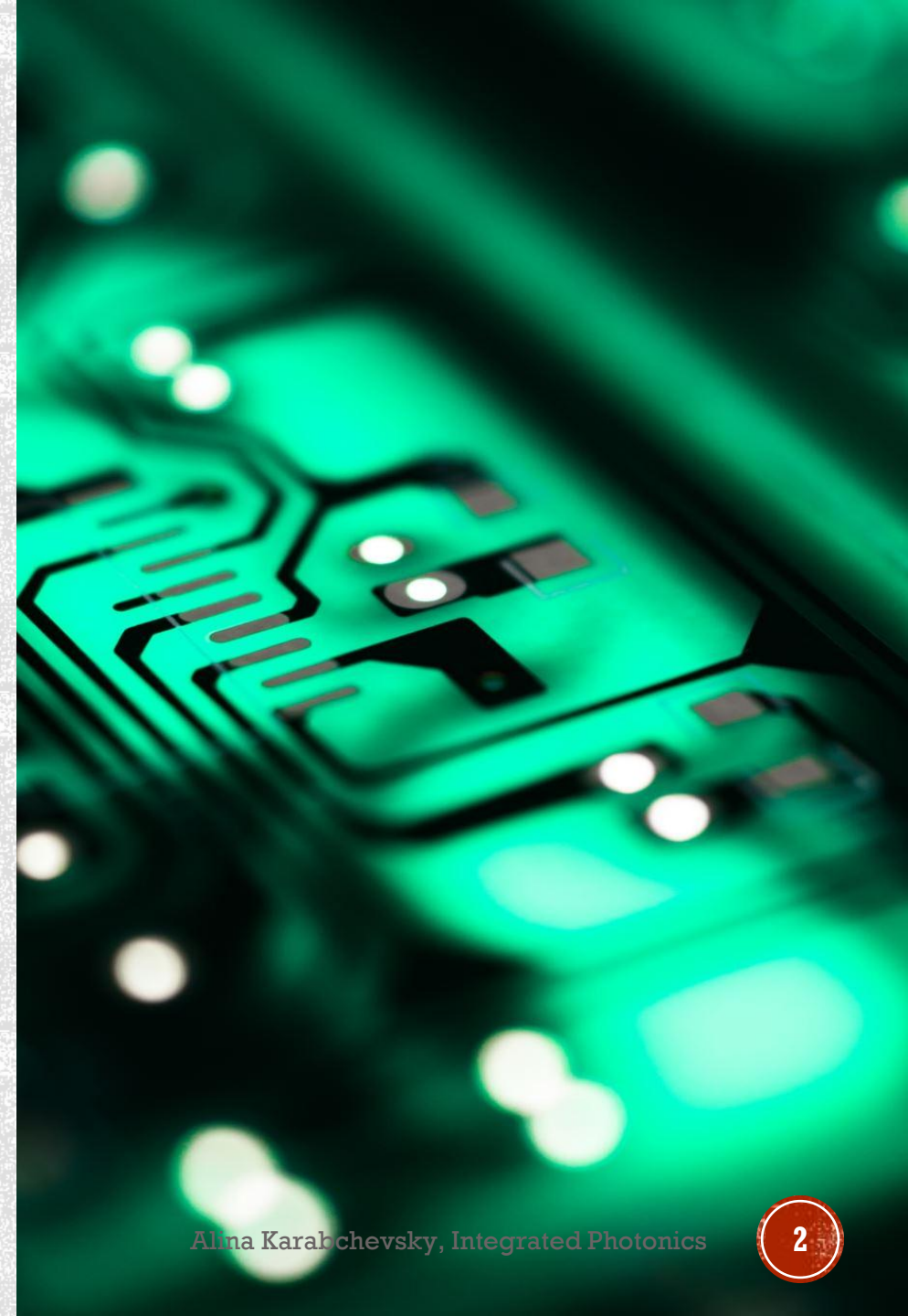

INDEX CONTROL



We will learn about methods in integrated photonics to control the refractive index of a material.



Why to change the refractive index?

Answer: the propagation characteristics dependent on the refractive index.



INDEX CONTROL METHODS

We will discuss three methods to control the refractive index:

- 1) **Changing the free carriers in a semiconductor** - the free carriers lower the refractive index and can prevent the propagation of certain wavelengths. Decreasing the free carriers will cause the propagation for certain wavelengths.
- 2) **Using the electro-optic effect** - in this effect, the refractive index is dependent on the electric field applied on the material.
- 3) **Growing layer in different methods:**
 - Epitaxial growth - changing the molar concentration.
 - Growing thin-film.
 - Ion implantation.
 - Ion diffusion.

CHANGING THE FREE CARRIERS IN SEMICONDUCTOR

The relation between the dielectric constant and the refractive index:

- In semiconductor, the dielectric constant (resulting refractive index) depends on free carriers (electrons or holes).
- Free carriers influence the material by decreasing the refractive index.
- Decreasing the free carriers, locally, will increase the refractive index and allow for propagation.

The complex refractive index is (n - real κ - imaginary):

$$n + j\kappa = \tilde{n} = \sqrt{\tilde{\epsilon}} = \sqrt{\tilde{\epsilon}_r + j\tilde{\epsilon}_i}$$

where $\tilde{\epsilon}_r$ and $\tilde{\epsilon}_i$ are the real and imaginary parts, respectively, of the dielectric constant (relative permittivity).

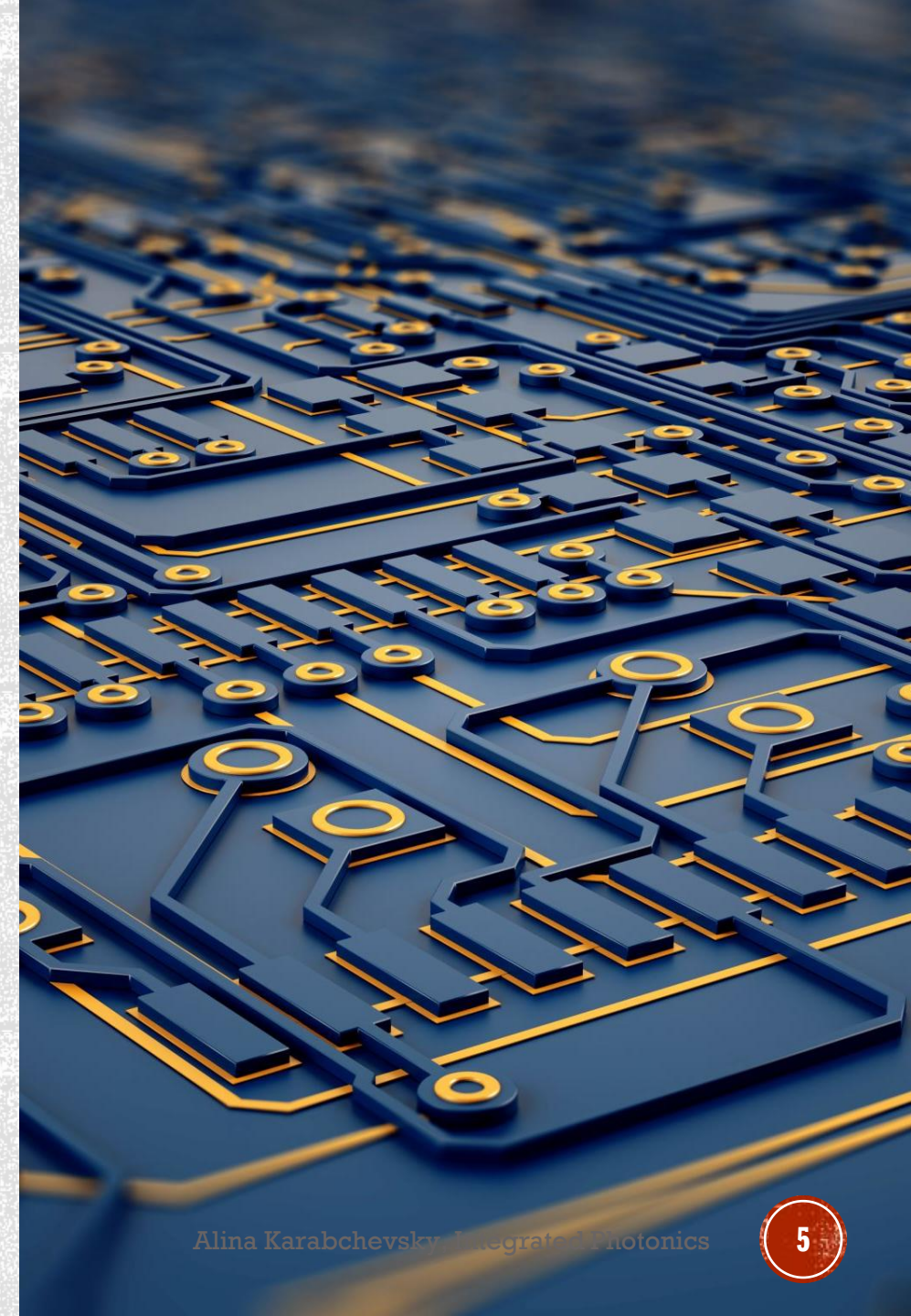

SEMICONDUCTOR DOPING - BASIC BONDS

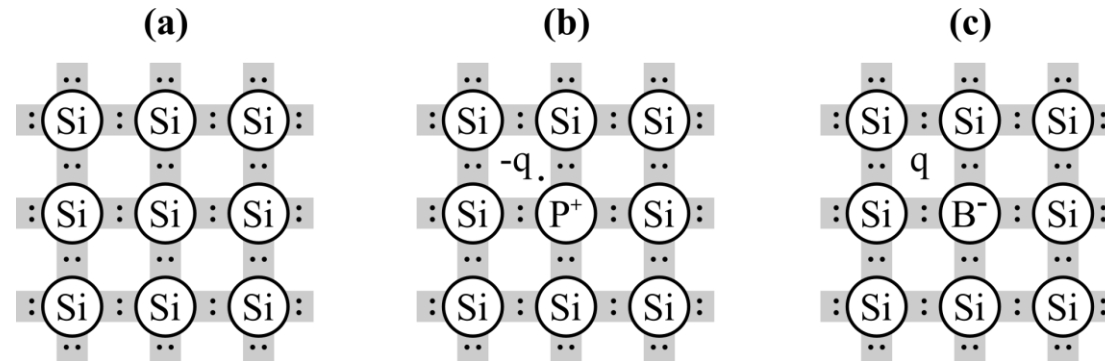

(a) Intrinsic silicon. (b) Silicon n-type doped with phosphorus (P) - donor. (c) Silicon p-type doped with boron (B) - acceptor; The “column” number represents the number of valence electrons.

II	III	IV	V	VI
	B	C	N	O
	Al	Si	P	S
Zn	Ga	Ge	As	Se
Cd	In	Sn	Sb	Te
Hg				

THE MEANING OF n AND κ

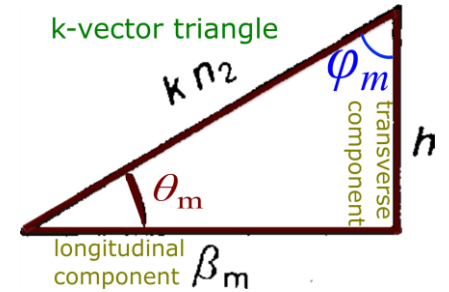

A wave propagates in a slab waveguide defined by:

$$E(x, y, z) = \vec{E}_y(x) e^{j\beta_m z}$$

$$\beta_m = k \cos(\theta_m) = k_0 n \cos(\theta_m) \quad k_0 = \frac{2\pi}{\lambda}$$

where β_m is the propagation constant in the z direction.

$$\begin{aligned} E(z) \propto e^{j\beta_m z} &\Rightarrow E(z) \propto e^{j\beta_m \tilde{n} z} \Rightarrow E(z) \propto e^{j\beta_m (n + j\kappa) z} \Rightarrow \\ &\Rightarrow E(z) \propto e^{j\beta_m n z} e^{-\beta_m \kappa z} \end{aligned}$$

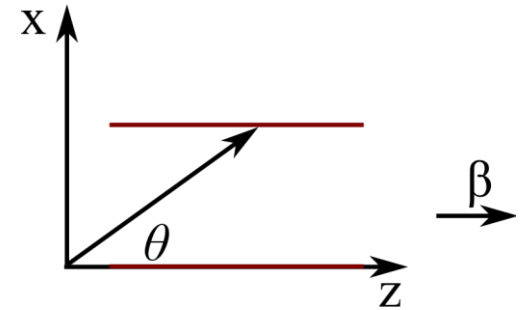

- The real part of the refractive index (n) is related to the propagation of the wave and it is important for guiding.
- The imaginary part of the refractive index (κ) is related to the absorption – the attenuation of the light in the material.

THE REAL AND THE IMAGINARY PARTS OF THE DIELECTRIC CONSTANT

The real and the imaginary parts of the dielectric constant are defined:

$$\tilde{\epsilon} = \tilde{\epsilon}_r + j\tilde{\epsilon}_i \quad \tilde{\epsilon}_r = n_0^2 - \frac{\omega_p^2}{\omega^2 + \frac{1}{\tau^2}} \quad \tilde{\epsilon}_i = \frac{\omega_p^2}{\omega\tau \left(\omega^2 + \frac{1}{\tau^2} \right)}$$

Where:

ω is the angular frequency: $\omega = 2\pi f = 2\pi c/\lambda = kc$

ω_p is the angular frequency of the plasma: $\omega_p = \sqrt{Nq^2/m^*\epsilon_0}$

q is the electron charge.

N is the concentration of the free carriers [cm^{-3}].

m^* is the relative mass of electron or hole.

n_0 is the refractive index in pure material. Theoretically only in 0K however in practice in GaAs when $N \leq 10^4 \text{ cm}^{-3}$.

ϵ_0 is the permittivity of free space.

τ is the lifetime of free carriers (recombination time or relaxation time). $\tau \approx 10^{-6} - 10^{-11} \text{ sec}$.

THE REAL AND THE IMAGINARY PARTS OF THE DIELECTRIC CONSTANT

$\frac{1}{\tau^2}$ is negligible compared to ω : $\omega \approx 10^{15} \gg \frac{1}{\tau}$

$$\tilde{\epsilon}_i = \frac{\omega_p^2}{\omega\tau \left[\omega^2 + \frac{1}{\tau^2} \right]} \Rightarrow \tilde{\epsilon}_i = \frac{\omega_p^2}{\omega^3 \cdot \tau}$$
$$\tilde{\epsilon}_r = n_0^2 - \frac{\omega_p^2}{\omega^2 + \frac{1}{\tau^2}} \Rightarrow \tilde{\epsilon}_r = n_0^2 - \frac{\omega_p^2}{\omega^2}$$

From the equations, we can see that the refractive index depends on ω_p , which in turn depends on N (the concentration of the free carriers).

Δn AS A FUNCTION OF THE CONCENTRATION OF FREE CARRIERS N

- In semiconductor, in visible and near-infrared : $\tilde{\epsilon}_r \gg \tilde{\epsilon}_i$
- Using Taylor series (the first two terms):

$$\tilde{n} = \sqrt{\tilde{\epsilon}_r + j\tilde{\epsilon}_i} = \sqrt{\tilde{\epsilon}_r} + j \frac{\tilde{\epsilon}_i}{2\sqrt{\tilde{\epsilon}_r}} \quad \tilde{n} = n_r + jn_i = n + j\kappa$$

Therefore, the real and the imaginary parts of the refractive index are:

$$n = \sqrt{\tilde{\epsilon}_r}$$

$$\kappa = \frac{\tilde{\epsilon}_i}{2\sqrt{\tilde{\epsilon}_r}}$$

Homework:

- 1) For GaAs, show that $\tilde{\epsilon}_r \gg \tilde{\epsilon}_i$.
- 2) Show that the derivation in Taylor series is correct.

DECREASING THE CONCENTRATION OF THE FREE CARRIERS IN A WAVEGUIDE

We showed that the real part of the refractive index is related to the wave propagation. Therefore, we focus on the change of \tilde{n} due to the changes in the concentration of the free carriers (N).

$$n_2^2 - n_3^2 = \Delta\epsilon_r = -\frac{\Delta(\omega_p^2)}{\omega^2} = \frac{(N_3 - N_2)q^2}{m^*\epsilon_0\omega^2}$$

$$\Delta n = n_2 - n_3 = \frac{(N_3 - N_2)q^2}{(n_2 + n_3)m^*\epsilon_0\omega^2}$$

Since the change in refractive index is very small $n_2 \approx n_3$:

$$\Delta n = n_2 - n_3 = \frac{(N_3 - N_2)q^2}{2n_2m^*\epsilon_0\omega^2}$$

DECREASING OF THE CONCENTRATION OF THE FREE CARRIERS IN WAVEGUIDE

Example:

Doping a semiconductor in a non-uniform distribution. In the area where we want the light to propagate, the doping is high; in the substrate the doping is low. N and n distribution are:

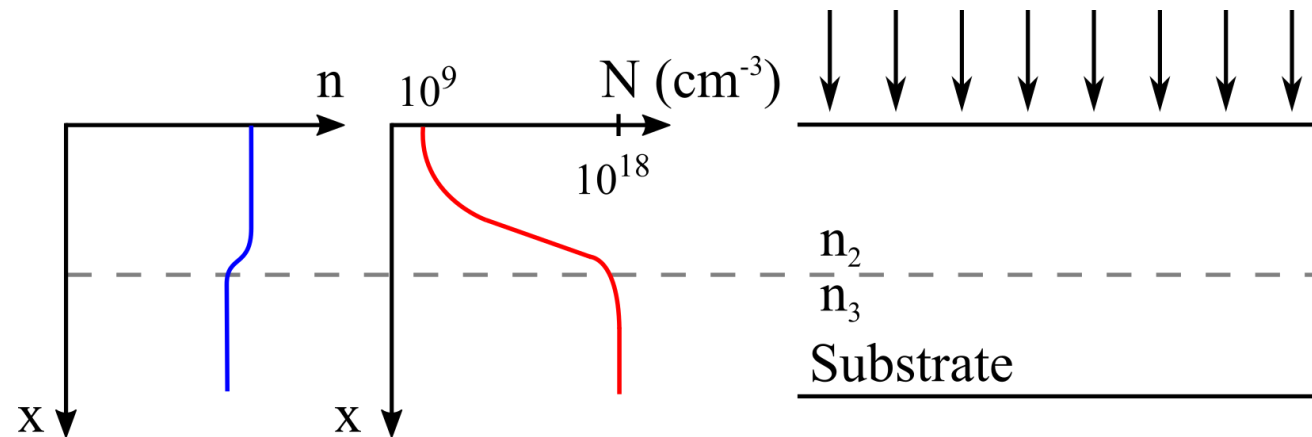

MILLER INDICES (HKL) IN CUBIC CRYSTALS

- Miller indices form a notation system in crystallography for lattice planes in crystal lattices.
- The values of the crystal are defined by the intercepts on the x , y and z axes.

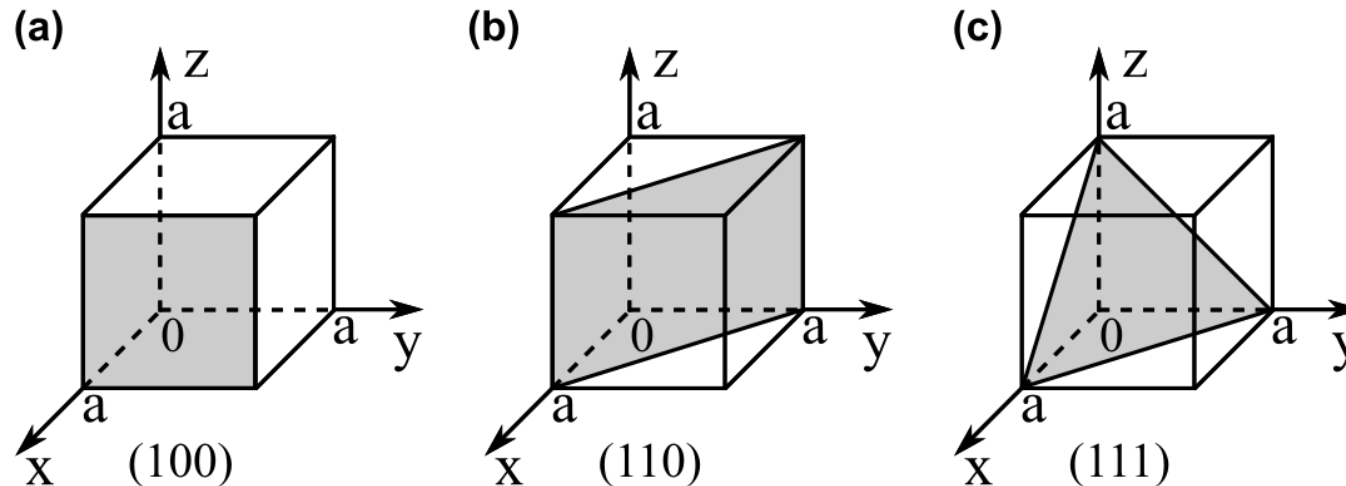

Figure 1: Miller indices (hkl) in cubic crystals.

ISOTROPIC MATERIALS

Distinguish between two types of materials: isotropic and anisotropic materials.

Isotropic material - the electric displacement field \vec{D} is proportional to the electric field \vec{E} as:

$$\vec{D} = \epsilon \vec{E}$$

where the permittivity is defined as: $\epsilon = \epsilon_0 \tilde{\epsilon}$

- The refractive index is uniform and not dependent on the polarization of the wave or the electric field direction.
- Mostly exists in non-crystalline materials such as glass and liquids.
- Materials that are used in integrated photonics: glass, diamond, calcium fluoride - (CaF_2) and Gallium arsenide (GaAs).

ANISOTROPIC MATERIALS

Anisotropic material - due to the crystal orientation, the internal dipoles are constrained to lie in particular directions with respect to the underlying material.

The electric displacement vector \vec{D} is not in the direction of the electric field \vec{E} :

$$\begin{bmatrix} D_x \\ D_y \\ D_z \end{bmatrix} = \epsilon_0 \begin{bmatrix} \epsilon_{11} & \epsilon_{12} & \epsilon_{13} \\ \epsilon_{21} & \epsilon_{22} & \epsilon_{23} \\ \epsilon_{31} & \epsilon_{23} & \epsilon_{33} \end{bmatrix} \cdot \begin{bmatrix} E_x \\ E_y \\ E_z \end{bmatrix}$$
$$\begin{bmatrix} P_x \\ P_y \\ P_z \end{bmatrix} = \epsilon_0 \begin{bmatrix} \chi_{11} & \chi_{12} & \chi_{13} \\ \chi_{21} & \chi_{22} & \chi_{23} \\ \chi_{31} & \chi_{23} & \chi_{33} \end{bmatrix} \cdot \begin{bmatrix} E_x \\ E_y \\ E_z \end{bmatrix}$$
$$\vec{P} = P_i = \epsilon_0 \underline{\chi} \vec{E} = \epsilon_0 \chi_{ij} E_i$$

Therefore, the refractive index depends on the polarization of the wave or the electric field direction.

ANISOTROPIC MATERIALS

- The refractive index depends on the polarization of the wave or the electric field direction.
- Usually, it is accepted to choose vertical directions - x , y and z in the crystal as the principal axes and three refractive indices - n_1 , n_2 and n_3 for the polarization in the direction of the axes.

$$n_1 = n_x, \quad n_2 = n_y, \quad n_3 = n_z \quad - \quad \text{Principle refractive indices}$$

We distinguish a sub-group named 'uniaxial crystals'. In this crystal, $n_1 = n_2$ and the refractive index is ordinary (o) for $n_1 = n_2 = n_o$ and extraordinary (e) for $n_3 = n_e$.

For $\lambda = 1.5 \mu\text{m}$:

SiO₂ (quartz)	$n_o = 1.5284$	$n_e = 1.5369$
TiO₂	$n_o = 2.4547$	$n_e = 2.7112$
LiNbO₃	$n_o = 2.2128$	$n_e = 2.139$



Friedrich Pockels (1865–1913) was first to describe the linear electro-optic effect in 1893.



John Kerr (1824–1907) discovered the quadratic electro-optic effect in 1875.

THE ELECTRO-OPTIC EFFECT

In the electro-optic effect, the refractive index depends on the electric field applied on the material (refractive index tensor). The field influences the grating structure, resulting in a change in the optical properties:

$$n' = n(E) \text{ when } E = 0 \Rightarrow n' = n$$

Using Taylor series:

$$n(E) = n' = n + a_1 E + \frac{1}{2} a_2 E^2 + \dots$$

Where a_1 is the **Pockels constant** and a_2 is the **Kerr constant**.

- Changing n by a_1 is the electro-optic effect of the first order named "Pockels effect".
- Changing n by a_2 is the electro-optic effect of the second order named "Kerr effect": $\Delta n = a_2 E^2 = K \lambda E^2$ where K is **Kerr coefficient**. Usually negligible in integrated photonic materials.

THE ELECTRO-OPTIC EFFECT

The electro-optic effect is described via the induced deformation of the index ellipsoid, which is defined as

$$\frac{x^2}{n_{xx}^2} + \frac{y^2}{n_{yy}^2} + \frac{z^2}{n_{zz}^2} + \frac{2yz}{n_{yz}^2} + \frac{2zx}{n_{zx}^2} + \frac{2xy}{n_{xy}^2} = 1$$

The electro-optical effect is defined through the index ellipsoid:

$$\left(\frac{1}{n^2}\right) = \frac{1}{n_{ij}^2(E_0)} = \left(\frac{1}{n_{ij}^2}\right)_0 + \sum_{j=1}^3 r_{ij} E_j + \sum_{j=1}^3 p_{ij,l} E_j E_l$$

where r_{ij} is linear electrooptical (Pockels) tensor and is tabulated in the literature for many crystals and $p_{\{i,j,l\}}$ is the quadratic electrooptical (Kerr) tensor where $i = 1, 2, 3, 4, 5, 6$

$$1 = (11) = (xx), \quad 2 = (22) = (yy), \quad 3 = (33) = (zz)$$

$$4 = (23) = (32) = (yz) = (zy)$$

$$5 = (13) = (31) = (xz) = (zx)$$

$$6 = (12) = (21) = (xy) = (yx)$$

and $j = 1, 2, 3$ is x, y, z respectively.

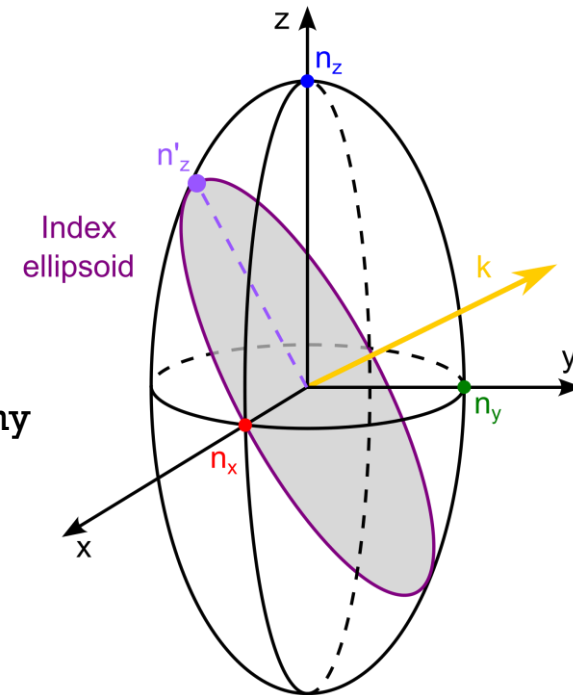

POCKELS EFFECT

$$- \Delta n = a_1 E$$

- If the axes parallel to the principal dielectric axes of the crystal

$$\Delta\left(\frac{1}{n^2}\right) = \sum_{j=1}^3 r_{ij} E_j$$

$$\begin{bmatrix} \Delta(1/n^2)_1 \\ \Delta(1/n^2)_2 \\ \Delta(1/n^2)_3 \\ \Delta(1/n^2)_4 \\ \Delta(1/n^2)_5 \\ \Delta(1/n^2)_6 \end{bmatrix} = \begin{bmatrix} r_{11} & r_{12} & r_{13} \\ r_{21} & r_{22} & r_{23} \\ r_{31} & r_{32} & r_{33} \\ r_{41} & r_{42} & r_{43} \\ r_{51} & r_{52} & r_{53} \\ r_{61} & r_{62} & r_{63} \end{bmatrix} \cdot \begin{bmatrix} E_x \\ E_y \\ E_z \end{bmatrix}$$

- The matrix is called the "linear electro-optic tensor"
- The r_{ij} are constant and known for each crystal.

POCKELS COEFFICIENTS r_{ij} FOR CRYSTALS

Cubic 43m

$$\begin{bmatrix} 0 & 0 & 0 \\ 0 & 0 & 0 \\ 0 & 0 & 0 \\ r_{41} & 0 & 0 \\ 0 & r_{41} & 0 \\ 0 & 0 & r_{41} \end{bmatrix}$$

(GaAs, CdTe, InAs)

Terragonal 42m

$$\begin{bmatrix} 0 & 0 & 0 \\ 0 & 0 & 0 \\ 0 & 0 & 0 \\ r_{41} & 0 & 0 \\ 0 & r_{41} & 0 \\ 0 & 0 & r_{63} \end{bmatrix}$$

(KDP, ADP)

Trigonal 3m

$$\begin{bmatrix} 0 & -r_{22} & r_{13} \\ 0 & r_{22} & r_{13} \\ 0 & 0 & r_{33} \\ 0 & r_{51} & 0 \\ r_{51} & 0 & 0 \\ -r_{22} & 0 & 0 \end{bmatrix}$$

(LiNbO₃, LiTaO₃)

POCKELS COEFFICIENTS r_{ij} FOR CRYSTALS

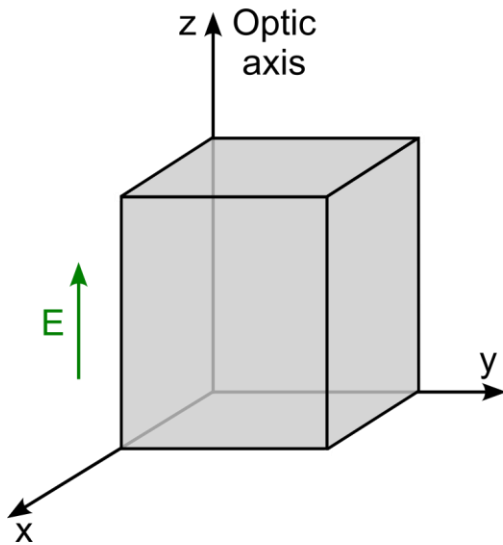

Cubic 43m

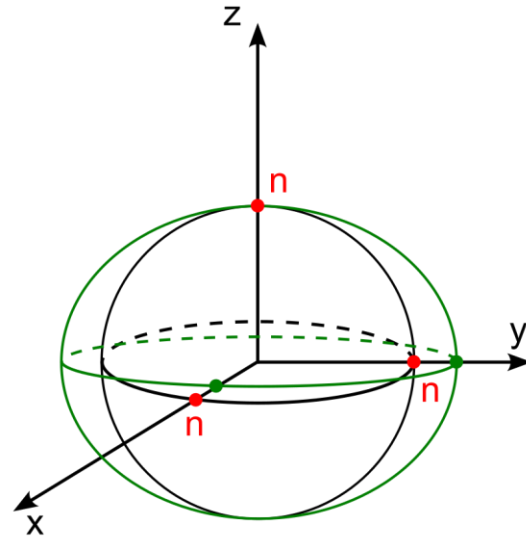

$$n_1(E) \approx n - \frac{1}{2}n^3r_{41}E$$

$$n_2(E) \approx n + \frac{1}{2}n^3r_{41}E$$

Terragonal 42m

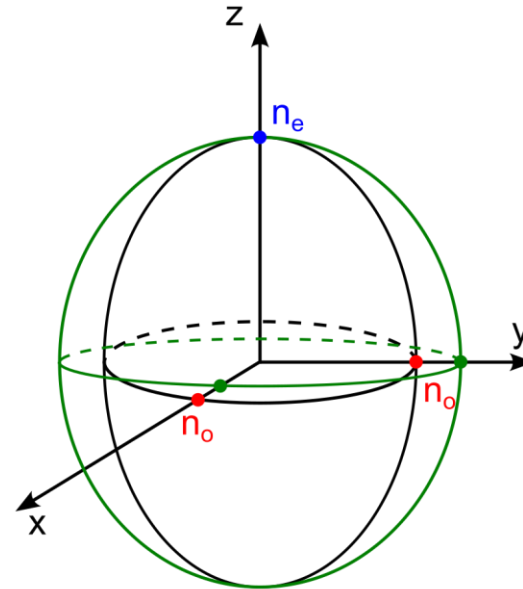

$$n_1(E) \approx n_o - \frac{1}{2}n_o^3r_{63}E$$

$$n_2(E) \approx n_o + \frac{1}{2}n_o^3r_{63}E$$

Trigonal 3m

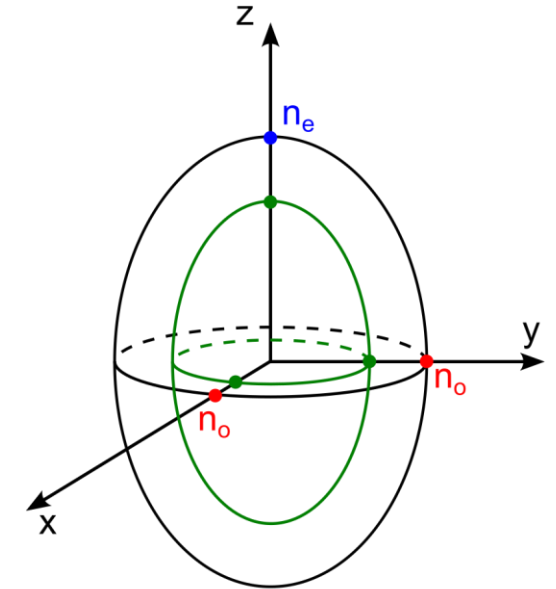

$$n_o(E) \approx n_o - \frac{1}{2}n_o^3r_{13}E$$

$$n_e(E) \approx n_e - \frac{1}{2}n_e^3r_{33}E$$

KERR COEFFICIENTS p_{ij} FOR AN ISOTROPIC MEDIUM

$$\begin{bmatrix} p_{11} & p_{12} & p_{12} & 0 & 0 & 0 \\ p_{12} & p_{11} & p_{12} & 0 & 0 & 0 \\ p_{12} & p_{12} & p_{11} & 0 & 0 & 0 \\ 0 & 0 & 0 & p_{44} & 0 & 0 \\ 0 & 0 & 0 & 0 & p_{44} & 0 \\ 0 & 0 & 0 & 0 & 0 & p_{44} \end{bmatrix}, \quad p_{44} = \frac{p_{11} - p_{12}}{2}$$

POCKELS EFFECT - $\Delta n = a_1 E$ [1]

Linear Electro-optic Coefficients of Some Commonly Used Crystals

Substance	Symmetry	Wavelength λ (μm)	Electro-optic Coefficients r_{ik} (10^{-12} m/V)	Index of Refraction n_i	$n^3 r$ (10^{-12} m/V)	Dielectric Constant ^a $\epsilon_i (\epsilon_0)$	
CdTe	$\bar{4}3m$	1.0	(T) $r_{41} = 4.5$	$n = 2.84$	103	(S) $\epsilon = 9.4$	
		3.39	(T) $r_{41} = 6.8$				
		10.6	(T) $r_{41} = 6.8$	$n = 2.60$	120		
		23.35	(T) $r_{41} = 5.47$	$n = 2.58$	94		
		27.95	(T) $r_{41} = 5.04$	$n = 2.53$	82		
GaAs	$\bar{4}3m$	0.9	$r_{41} = 1.1$	$n = 3.60$	51	(S) $\epsilon = 13.2$	
		1.15	(T) $r_{41} = 1.43$	$n = 3.43$	58	(T) $\epsilon = 12.3$	
		3.39	(T) $r_{41} = 1.24$	$n = 3.3$	45		
		10.6	(T) $r_{41} = 1.51$	$n = 3.3$	54		
GaP	$\bar{4}3m$	0.55–1.3	(T) $r_{41} = -1.0$	$n = 3.66\text{--}3.08$		(S) $\epsilon = 10$	
		0.633	(S) $r_{41} = -0.97$	$n = 3.32$	35		
		1.15	(S) $r_{41} = -1.10$	$n = 3.10$	33		
		3.39	(S) $r_{41} = -0.97$	$n = 3.02$	27		
LiNbO ₃ ($T_c = 1230$ °C)	$3m$	0.633	(T ₄) $r_{13} = 9.6$	(S) $r_{13} = 8.6$	$n_o = 2.286$	(T) $\epsilon_1 = \epsilon_2 = 78$	
			(T) $r_{22} = 6.8$	(S) $r_{22} = 3.4$	$n_e = 2.200$	(T) $\epsilon_2 = 32$	
			(T) $r_{33} = 30.9$	(S) $r_{33} = 30.8$		(S) $\epsilon_1 = \epsilon_2 = 43$	
			(T) $r_{51} = 32.6$	(T) $r_{51} = 28$		(S) $\epsilon_3 = 28$	
		1.15	(T) $r_c = 21.1$				
			(T) $r_{22} = 5.4$		$n_o = 2.229$		
			(T) $r_c = 19$		$n_e = 2.150$		
			(T) $r_{22} = 3.1$	(S) $r_{33} = 28$	$n_o = 2.136$		
3.39	(T) $r_c = 18$	(S) $r_{22} = 3.1$	$n_e = 2.073$				
		(S) $r_{13} = 6.5$					
		(S) $r_{51} = 23$					
KH ₂ PO ₄ (KDP)	$\bar{4}2m$	0.546	(T) $r_{41} = 8.77$	$n_o = 1.5115$		(T) $\epsilon_1 = \epsilon_2 = 42$	
			(T) $r_{63} = 10.3$	$n_e = 1.4698$		(T) $\epsilon_3 = 21$	
		0.633	(T) $r_{41} = 8$	$n_o = 1.5074$		(S) $\epsilon_1 = \epsilon_2 = 44$	
			(T) $r_{63} = 11$	$n_e = 1.4669$		(S) $\epsilon_3 = 21$	
		3.39	(T) $r_{63} = 9.7$				
	(T) $n_o^3 r_{63} = 33$						

(T) = low frequency from dc through audio range; (S) = high frequency.

ELECTRO-OPTIC MODULATOR

When the Schottky diode is in reverse bias V , the electric field causes a phase shift of the light wave in the guiding layer. For (100) crystal, the change of the refractive index is caused by TE polarized field (polarized along the y plane) wavelength of $1.15 \mu\text{m}$:

$$\Delta n = \Delta n_y = n^3 r_{41} \frac{V}{2t_g}$$

where n is the refractive index without applied field.

The phase shift caused by the field is:

$$\Delta\varphi_{\text{EO}} = \Delta\beta L = \frac{\pi}{\lambda_0} n_0^3 r_{41} \frac{VL}{t_g}$$

where L is the length of the modulator.

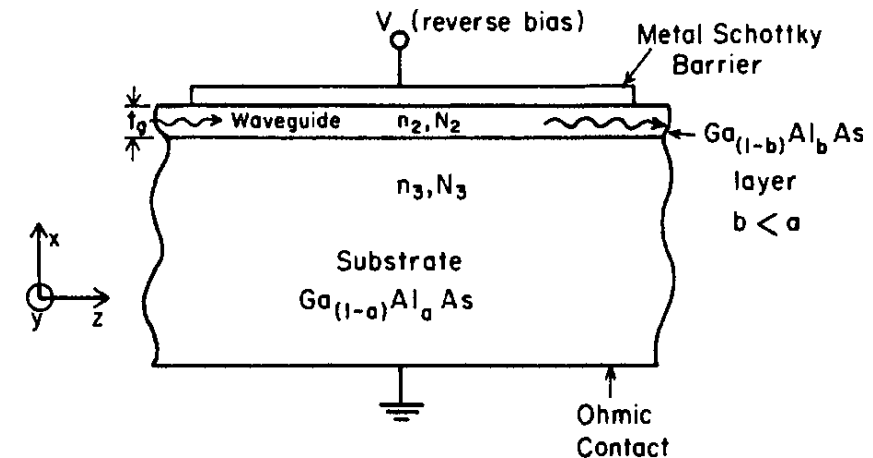

From [1]

ELECTRO-OPTIC MODULATORS

An electro-optic modulator can be a single-waveguide or a dual-waveguide modulators. Traveling voltage wave produces a similarly moving pattern of changed index of refraction in the underlying waveguide.

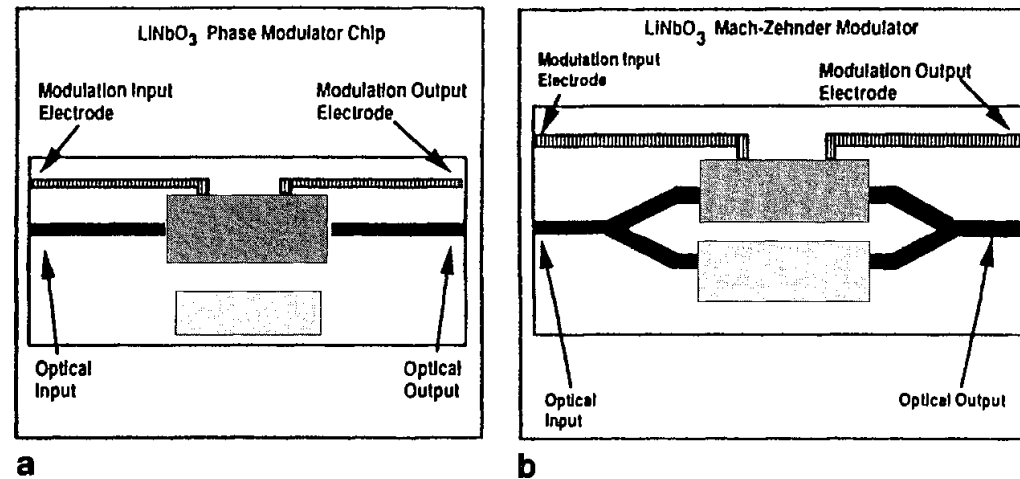

Figure 1: Waveguide modulators with traveling wave electrodes in LiNbO₃: (a) phase modulator and (b) Mach-Zehnder modulator [2].

MACH-ZEHNDER MODULATOR

A Mach-Zehnder can be used for amplitude modulator by creating phase shift in one of its arms.

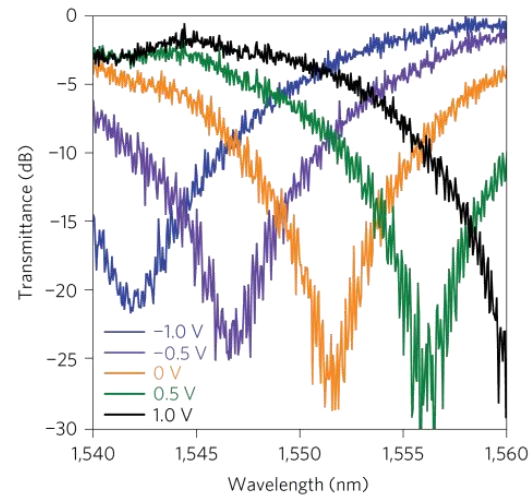
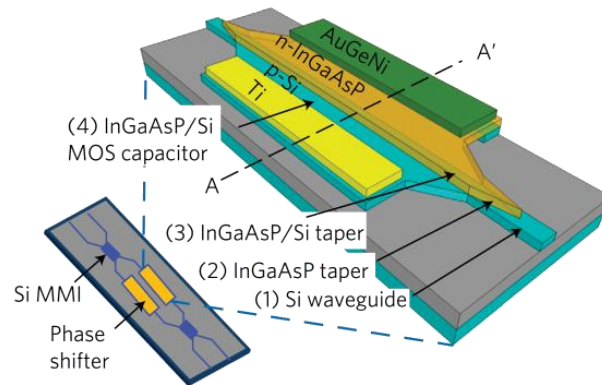
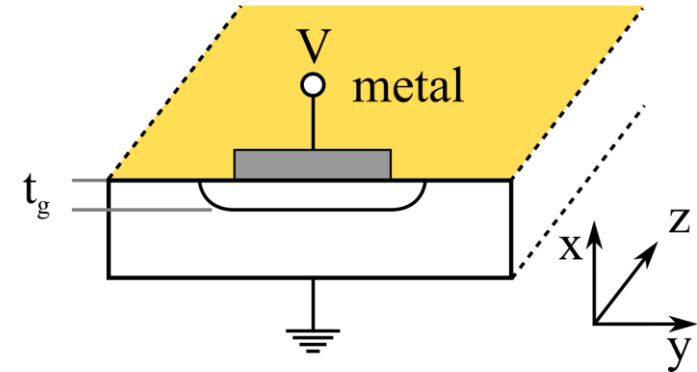

Figure 2: (a) Schematic of the InGaAsP/Si MOS capacitor MZ modulator. (b) Measured spectrum of an MZ modulator with 700 μm long phase shifter as a function of applied voltage. [3]

EXAMPLES



Example 1: GaAs

For (100) crystal (the orthogonal vector is $[1,0,0]$) for TE polarized field with TE polarized field (E_y):

$$n_x = n_1' = n_o + \frac{1}{2} n_o^3 r_{41} E$$

$$n_y = n_2' = n_o - \frac{1}{2} n_o^3 r_{41} E$$

$$n_z = n_3' = n_o$$

The waveguide is made of a Schottky diode. When the field is activated, a depletion region is created under the metal layer. In this area, there is a guiding layer - the refractive index depends on the field.

The wave propagates in the z direction and the field is in the y direction (TE). The change in the refractive index for (100) crystal in TE polarization:

$$\Delta n = n_o^3 r_{41} \frac{V}{2t_g}$$

EXAMPLES

For (100) GaAs or GaAlAs crystal in TE polarization:

$$\Delta n = n_o^3 r_{41} \frac{V}{2t_g}$$

n_o - the refractive index without field.

r_{41} - element (4,1) from the electro-optic tensor.

$n_o^3 r_{41}$ - the electro-optic constant.

V - smaller than the breakout voltage V_{BR} .

V around 100 V is enough to create a depletion region with a thickness of 1 μm .

Wavelength of 900 nm

$$\Delta n = 3.6^3 \cdot 1.1 \cdot 10^{-12} \frac{100}{2 \cdot 10^{-6}} = 3.5 \cdot 10^{-3}$$



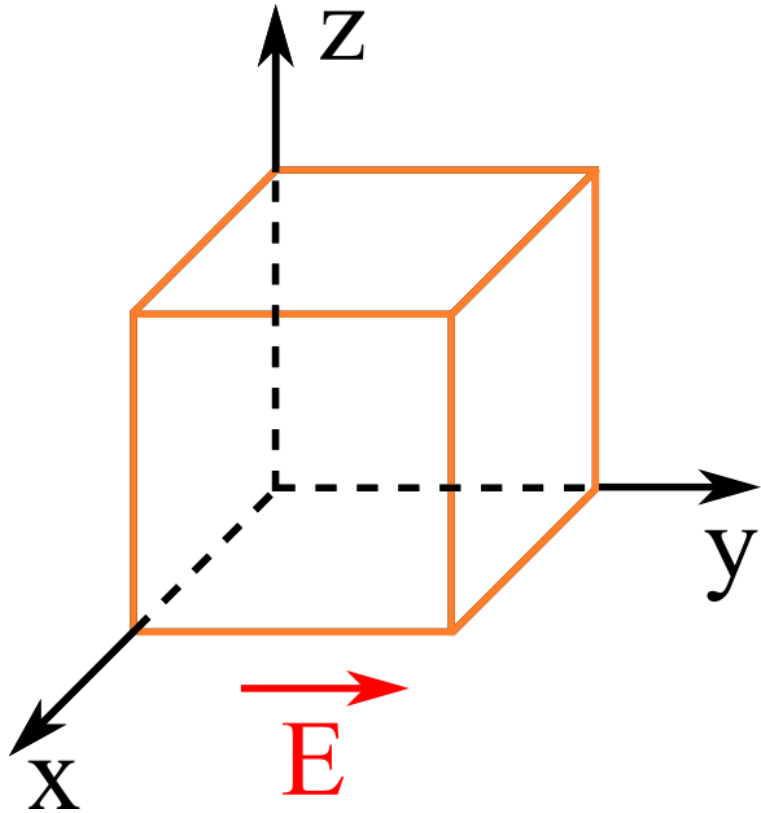

EXAMPLES

Example 2: Glass

Glass is not influenced by the electric field.

Example 3: LiNbO₃

We choose z as the main optical axis:

$$n_1 = n_2 = n_o \quad n_1 = n_x \quad n_2 = n_y \quad n_3 = n_z = n_e$$

First case: Activating external field in the y direction

$$n_x = n_1' = n_o + \frac{1}{2} n_o^3 r_{22} E$$

$$n_z = n_3' = n_e - \frac{1}{2} n_e^3 r_{51} E$$

Where:

$$r_{22} = 3.45 \times 10^{-12} \text{ (m/V)}$$

$$r_{51} = 28 \times 10^{-12} \text{ (m/V)}$$

$$n_o = 2.272 \quad n_e = 2.187$$

FABRICATION OF A WAVEGUIDE

Methods of fabricating waveguides for optical integrated circuits:

- 1) Deposited thin films (glass, nitrides, oxides, organic polymers).
- 2) Photo resist films.
- 3) Ion bombarded glass.
- 4) Diffused dopant atoms.
- 5) Heteroepitaxial layer growth.
- 6) Electro-optic effect.
- 7) Metal film stripline.
- 8) Ion migration.
- 9) Reduced carrier concentration in a semiconductor.
 - Epitaxial layer growth.
 - Diffusion.
 - Ion implantation.



EPITAXIAL GROWTH

EPITAXIAL GROWTH - CHANGING THE MOLAR CONCENTRATION

- In integrated optics on monolithic circuits made of semiconductors, epitaxial growth is a widely used method for fabricating waveguides.
- This method allows changing the chemical composition of the layer growth to fit the needed molar concentration and wavelength.
- With this method, we fabricate the common waveguide made of a layer of $\text{Ga}_{1-x}\text{Al}_x\text{As}$ on a substrate of GaAs.

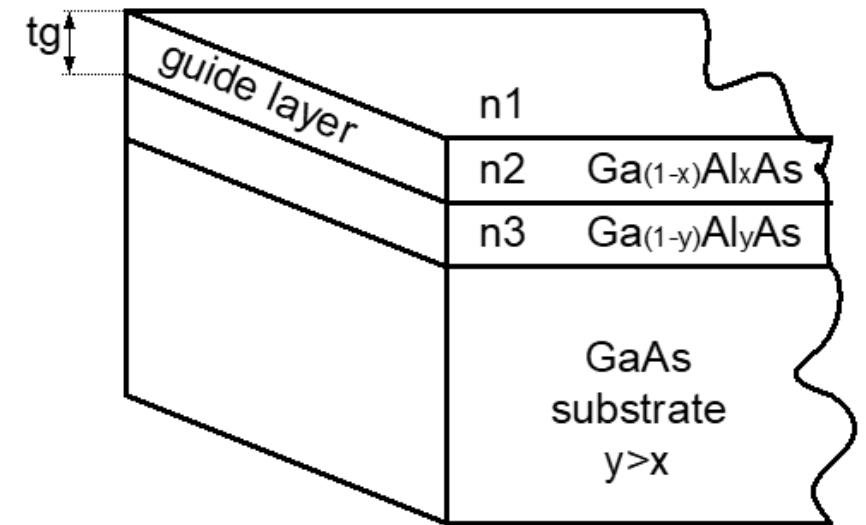

From [1]

EPITAXIAL GROWTH - CHANGING THE MOLAR CONCENTRATION

For $\text{Ga}_{1-x}\text{Al}_x\text{As}$, the refractive index depends on the molar concentration of the aluminum (x). It allows waveguide fabrication by only changing x . As x is getting bigger, the refractive index n is getting smaller as shown in the graph below.

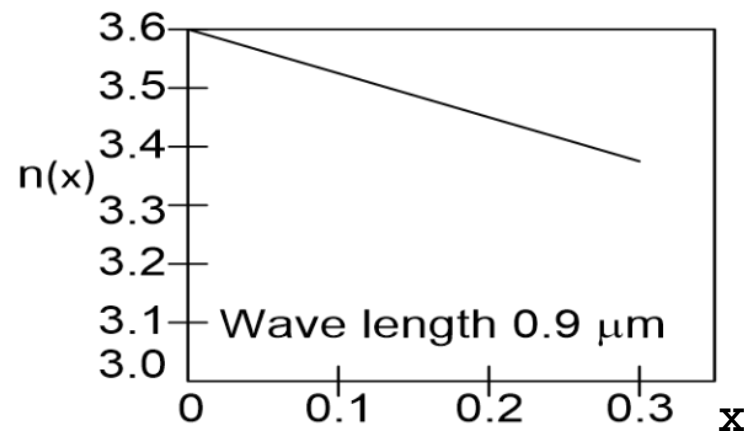
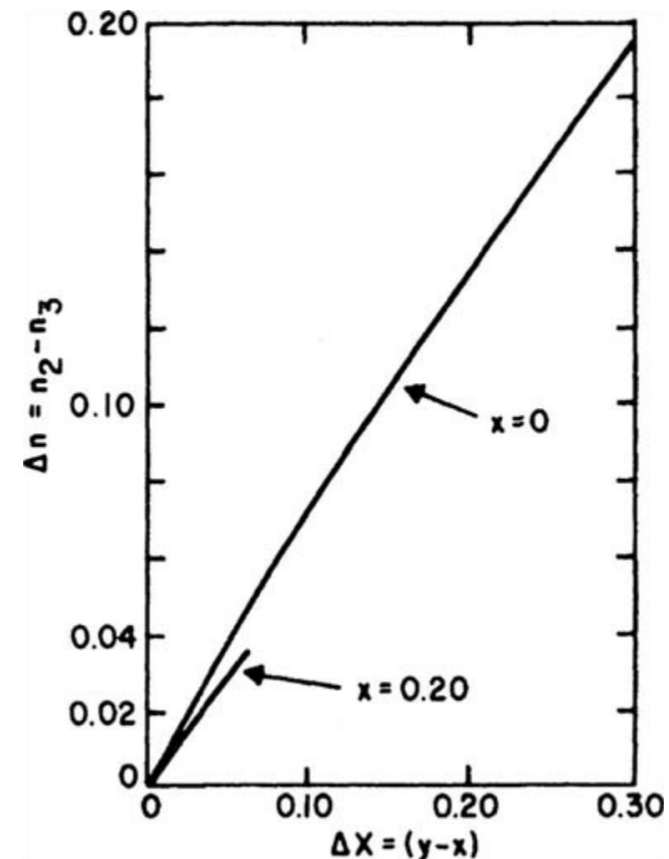
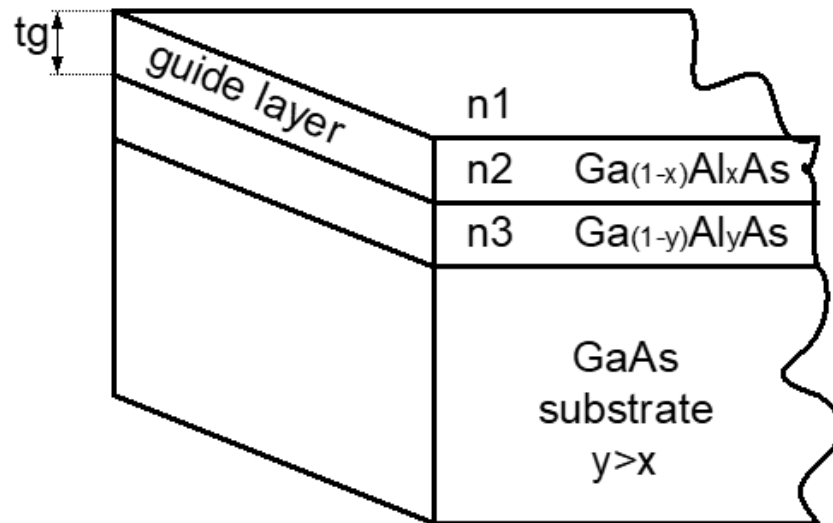

Figure 3: Refractive index of $\text{Ga}_{1-x}\text{Al}_x\text{As}$ as a function of x for a wavelength of 0.9 μm .

EPITAXIAL GROWTH - CHANGING THE MOLAR CONCENTRATION

The difference in the refractive indices as a function of the difference in the Al concentration between two layers of $\text{Ga}_{1-x}\text{Al}_x\text{As}$ [1].



EPITAXIAL GROWTH - CHANGING THE MOLAR CONCENTRATION

The ratio between the refractive indices and wavelength as a function of the difference in the Al concentration between two layers of $\text{Ga}_{1-x}\text{Al}_x\text{As}$ [1].

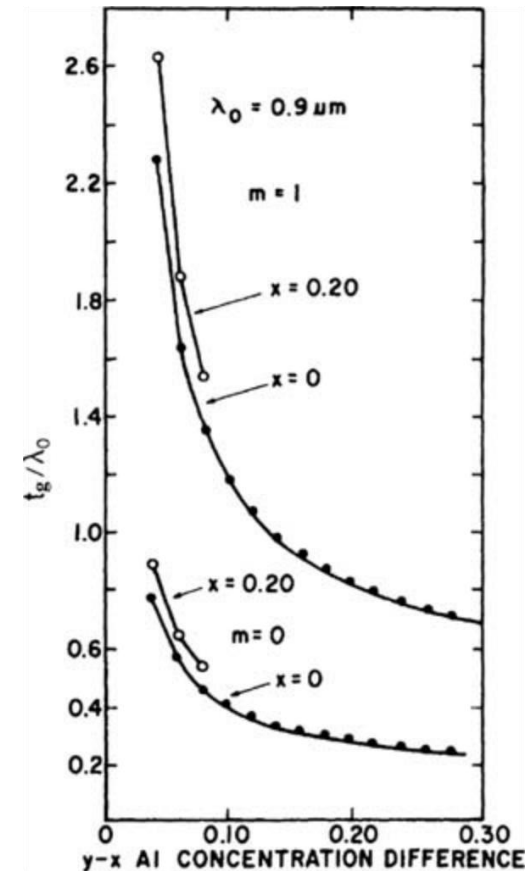
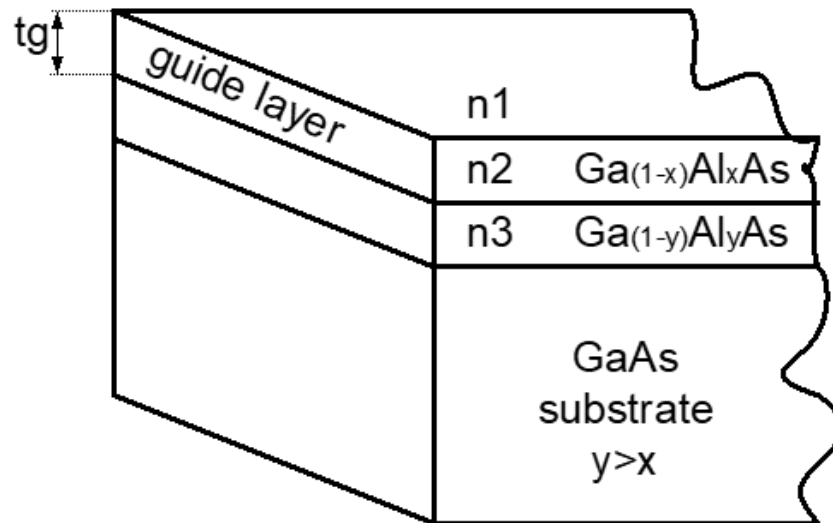

EPITAXIAL GROWTH - CHANGING THE MOLAR CONCENTRATION

The distance between the atoms in GaAs and AlAs is very close:

- Allows preventing defects in the material.
- Allows using material that contains two different x .

Two grating structures are common in semiconductors when every central atom is equidistant to four atoms.

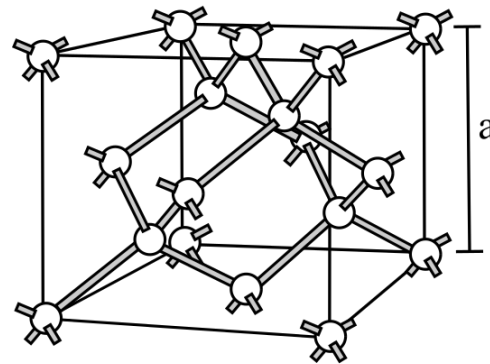

Diamond
(C, Ge, Si, etc)

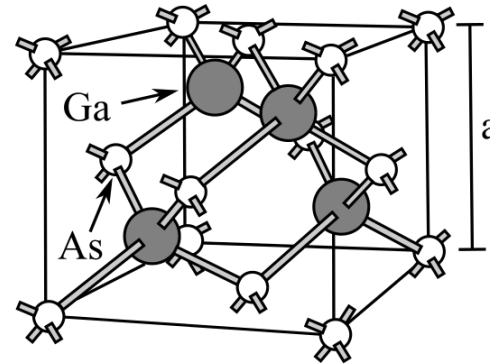

Zincblende
(GaAs, GaP, etc)

EPITAXIAL GROWTH - SELLMIEIER EQUATION

The Sellmeier equation defines the refractive index as a function of the wavelength:

$$n(\lambda[\mu\text{m}])^2 = 1 + \sum_i \frac{A_i \lambda^2}{\lambda^2 - B_i}$$

Where A_i and B_i are the Sellmeier coefficients and λ is the vacuum wavelength in micrometers.

EPITAXIAL GROWTH - SELLMIEIER EQUATION

Sellmeier equation that fits the GaAs and Ga_{1-x}Al_xAs is:

$$n(x)^2 = A(x) + \frac{B}{\lambda_0^2 - C(x)} - D(x)\lambda_0^2$$

where A , B , C and D depend on x as:

Material	A	B	C	D
GaAs	10.906	0.97501	0.27969	0.002467
Ga _(1-x) Al _x As	10.906 - 2.92x	0.97501	(0.52886 - 0.735x) ² x ≤ 0.36 (0.30386 - 0.105x) ² x ≥ 0.36	(0.002467)(1.41x + 1)

LIQUID PHASE EPITAXY (LPE)

- Liquid-phase epitaxy (LPE) is a method to grow semiconductor crystal layers from the melt on solid substrates.
- The growth of $\text{Ga}_{1-x}\text{Al}_x\text{As}$ epitaxial layers on a GaAs Substrate for OIC fabrication is usually carried out by liquid phase epitaxy (LPE), in a tube furnace, at temperatures in the range from 700 to 900C.

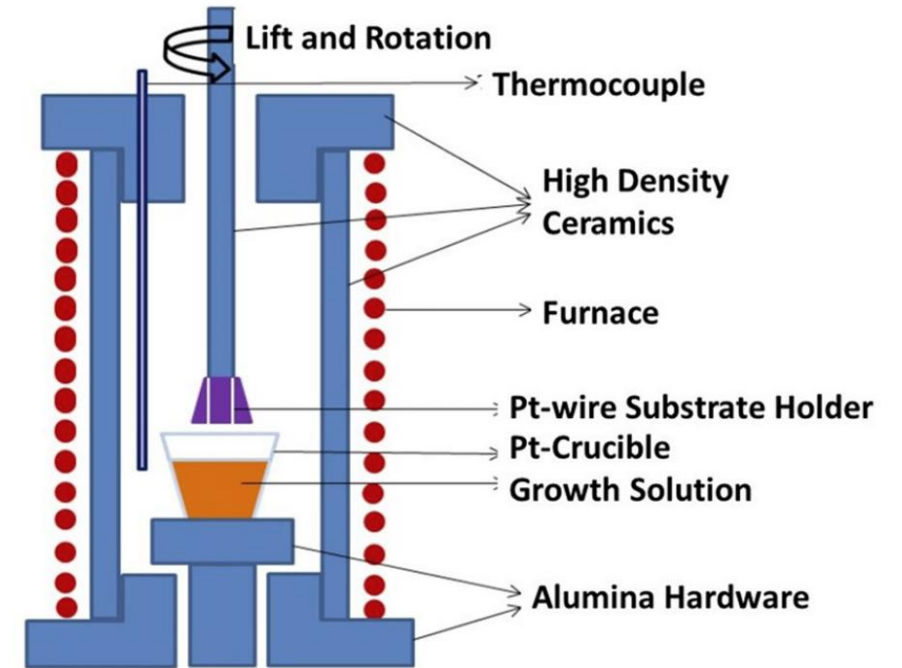

Liu, Ying, et al. "Strain induced anisotropy in liquid phase epitaxy grown nickel ferrite on magnesium gallate substrates." Scientific Reports 12.1 (2022): 7052.

MOLECULAR BEAM EPITAXY (MBE)

- Certain atoms are delivered to the substrate during the growth by accelerated molecules (or atoms).
- The crystal is placed in an Ultra-High-Vacuum (UHV) chamber. Each cell contains different material which can be heated and emits atoms beam. It allows growing material with the needed doping.

The advantages of this method:

1. Control of doping.
2. Control of the thickness.

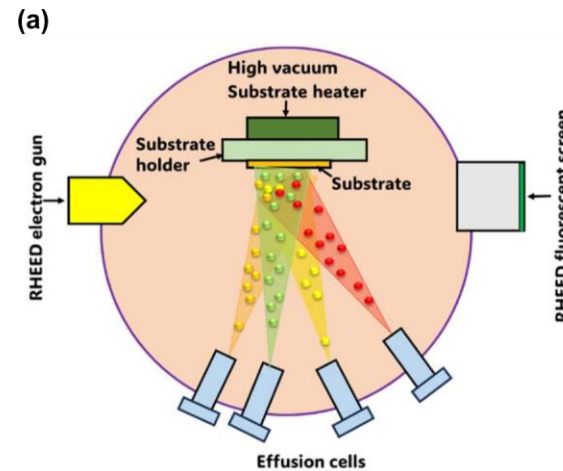

METAL-ORGANIC CHEMICAL VAPOR DEPOSITION (MOCVD)

- The constituent atoms are delivered to the substrate as a gaseous flow within a growth reactor furnace.
- Metal-organic gases such as PH_2 , AsH_2 , TEGa , TEIn and THAl are used.
- The substrate temperature during growth is typically 750°C .
- It offers precise control of dopant concentration and layer thickness and can be used with large area substrate wafers.

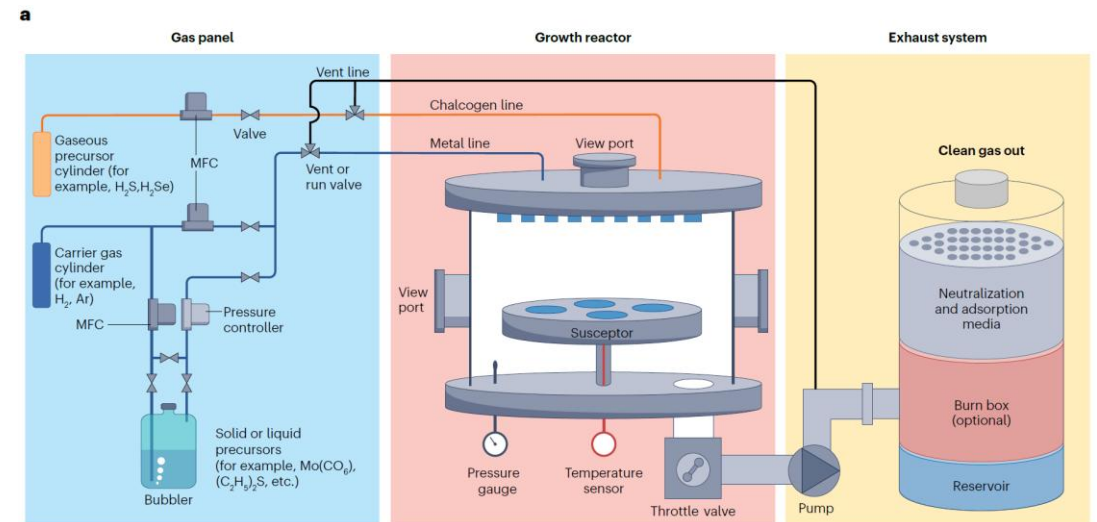

Zhang, Xiaotian, et al. "Metal-organic chemical vapour deposition for 2D chalcogenides." *Nature Reviews Methods Primers* 5.1 (2025): 57.



THIN FILMS

THERMAL EVAPORATION

- High current flows in a metal filament (e.g. tungsten, molybdenum).
- A solid target material inside a high vacuum chamber, typically 3×10^{-4} Torr, is heated by the filament. The material in the target is heated up until it evaporates.
- The vacuum allows the evaporation of the metal on the substrate and the creation of the metal layer (non-uniform layer).

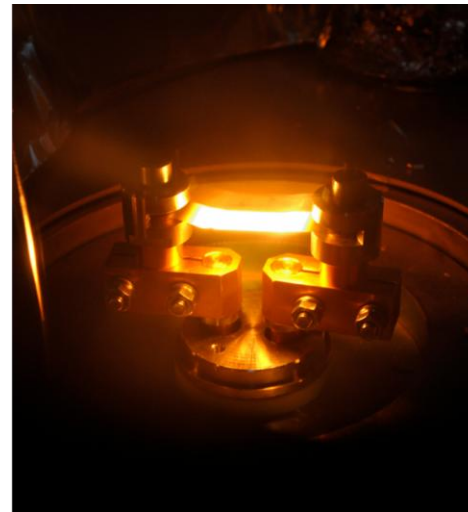
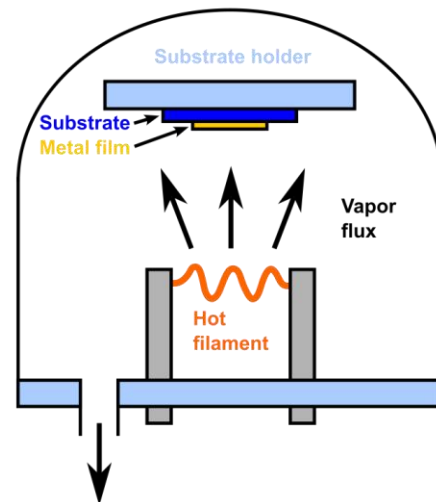

E-BEAM EVAPORATION

- Instead of wire, there is an electron gun.
- The electrons hit the target and evaporate it.
- The atoms hit the substrate and create a metal layer (non-uniform layer).

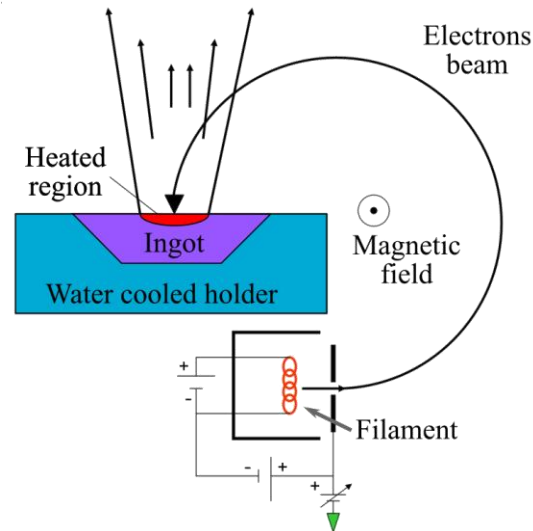

SPUTTERED DIELECTRIC FILMS

- Thermally stimulated vacuum-evaporation for AR coatings is not good for waveguide fabrication - lossy films with 10 dB/cm due to the inclusion of contaminant atoms that act as absorption and scattering centers.
- **Sputtering** is the process in which atoms or molecules are removed from the surface of a source (target) material, in a vacuum, by bombardment with ions having energies in excess of about 30 eV to about 2 keV - kinetically distributed atoms over the surface with losses on the order of 1 dB/cm.

SPUTTERING SYSTEM

- Atoms or molecules are removed from the source (target) material bombardment with ions, with energies about 30 eV - 2 keV, in a vacuum.
- The atoms (or molecules) are deposited on the surface of a substrate, forming a thin film layer.
- This process produces a very uniform layer because the deposited atoms are kinetically distributed over the surface.

PLASMA DISCHARGE SYSTEM

- The target and substrate are placed in a vacuum system and a gas is let in at a pressure of $(2 - 20) \times 10^{-3}$ torr.
- A high voltage bias is applied between the anode and the cathode.
- Ions generated in the plasma discharge are accelerated toward the cathode.
- The atoms near the surface of the target material, which are thereby sputtered off, and then deposited on the substrate.

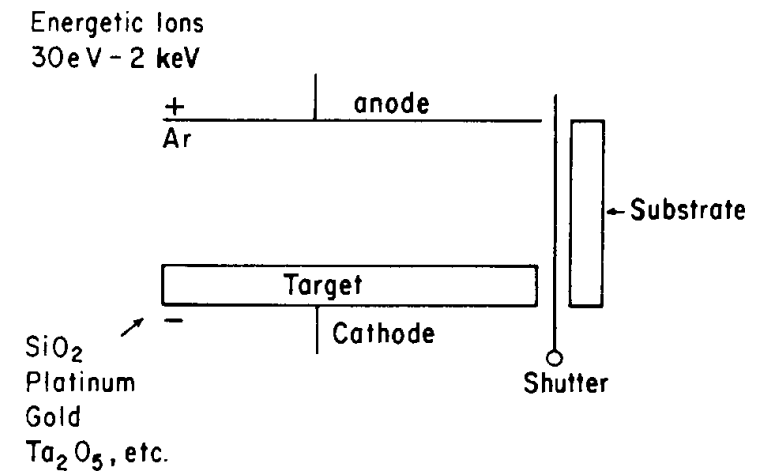

From [1]

ION BEAM SPUTTER DEPOSITION

- A collimated beam of ions, produced by an ion gun, hit the target.
- The advantages is that the deposition can be done in a high vacuum $< 10^{-6}$ torr, and that the focused ion beam strikes only the target. No contaminant atoms are sputtered off the walls of the chamber.
- Since the focused ion beam is often smaller than the target, the beam is usually electrically scanned in a raster pattern over the target to ensure uniform sputtering.

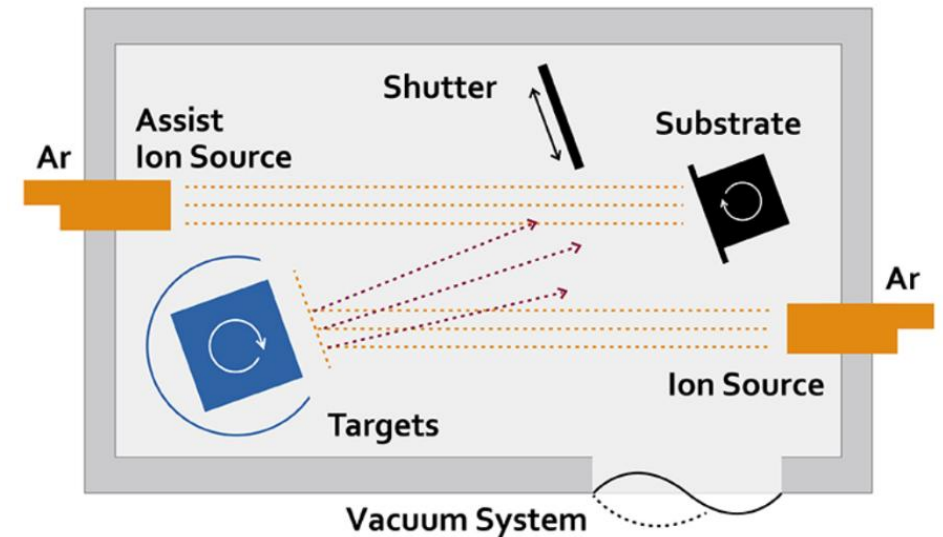
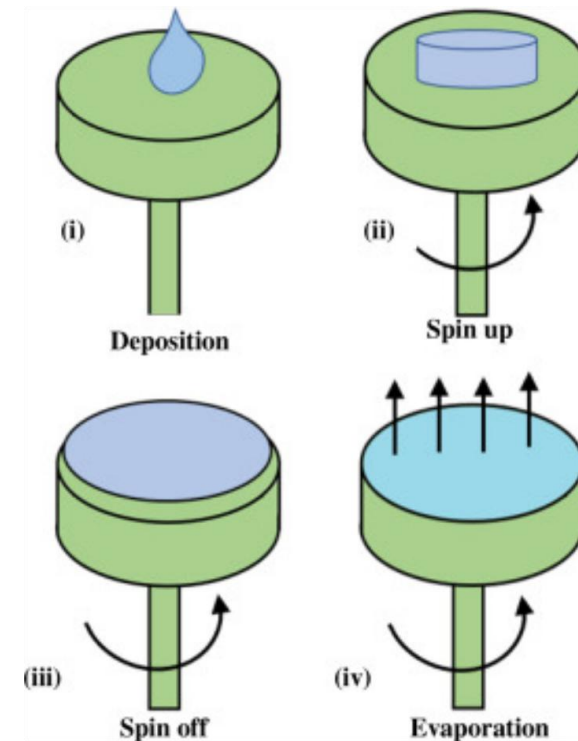

Figure 4: Ion beam sputter deposition [from DentonVacuum]

SPIN-COATING FROM SOLUTIONS

- Spin coating is a procedure used to deposit a uniform thin film onto a flat substrate. A small amount of coating material is applied on the center of the substrate. The substrate is then rotated at high speed in order to spread the coating material by centrifugal force.
- The advantages of spin coating are simplicity and relative ease.



SPIN-COATING FROM SOLUTIONS

- Spin coating is a procedure used to deposit a uniform thin film onto a flat substrate. A small amount of coating material is applied on the center of the substrate. The substrate is then rotated at high speed in order to spread the coating material by centrifugal force.
- The advantages of spin coating are simplicity and relative ease.

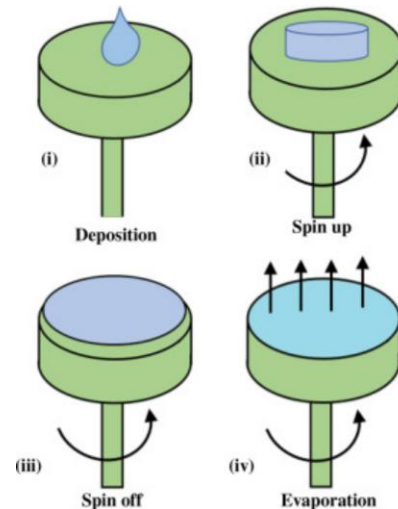

SPIN-COATING FROM SOLUTIONS

- Spin-coating of PMMA with 0.3 dB/cm loss at 1300 nm.
- Polyimide channel waveguides fabricated by direct laser writing.

Waveguide materials applied by spinning and dipping

Material	Solvent
Photoresist	Acetone
Epoxy	Proprietary Compounds
Polymethylmethacrylate	Chloroform, Toluene
Polyurethane	Xylene
Polyimide	
Spun-on glass (SOG)	

POLYMER WAVEGUIDES

- Polymers such as halogenated acrylate, fluorinated polyimide, and deuterated polymethylmethacrylate (PMMA) have been used.
- Polymer films can be fabricated on top of Si, glass, quartz, or plastic through spin coating.
- The photoresist layer on top is used for reactive ion etching of the core layer through a photomask.

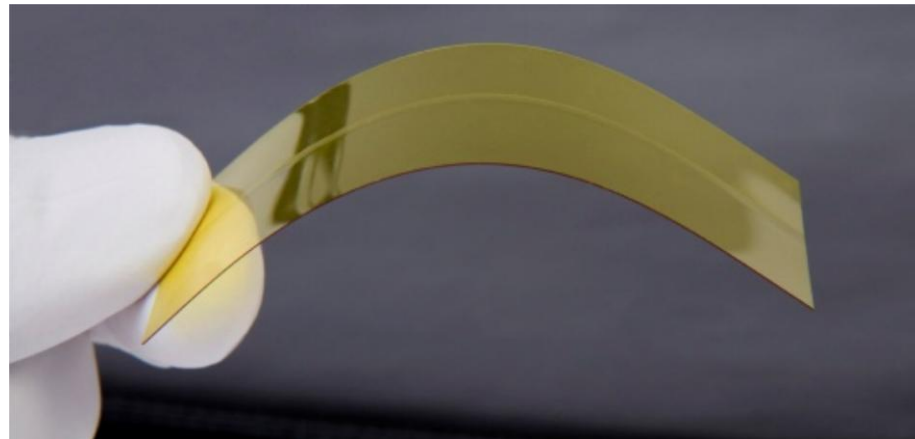



SUBSTITUTIONAL DOPANT ATOMS

ION IMPLANTATION

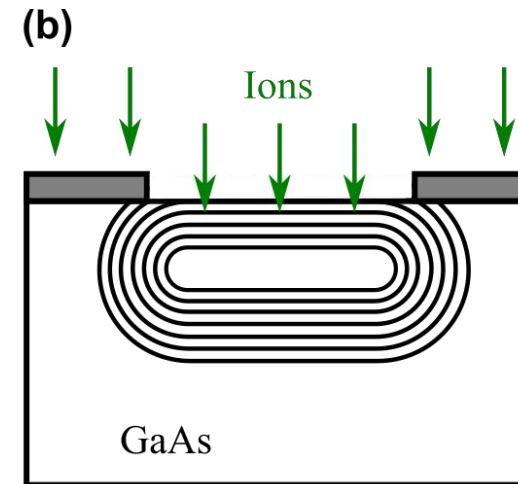
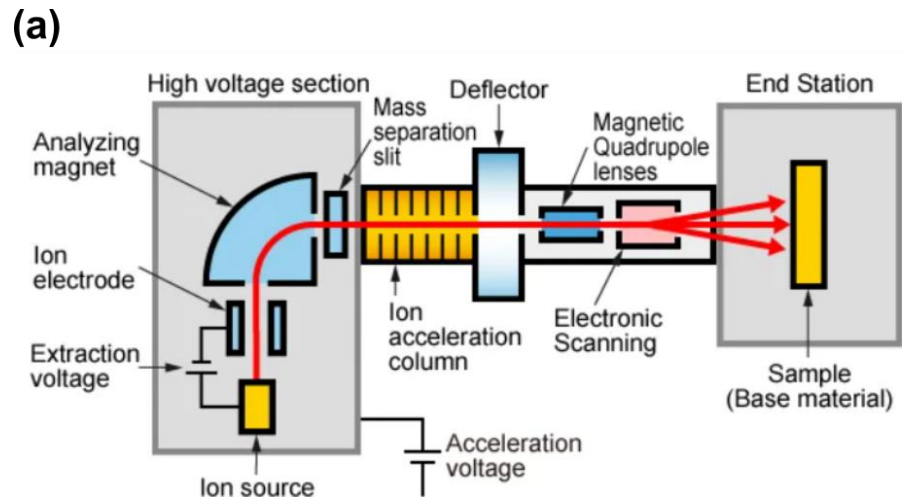

- Accelerating ions in high energy that fits to ion penetration to the substrate.
- The penetrating ions' distribution is Gaussian (as a function of the penetration depth). The penetration depth R_p and the width of the Gaussian depends on the concentration and mass of the ions.
- The drawback of this method is that defects are created in the substrate which can be solved by relaxation using heat.

ION IMPLANTATION SYSTEM

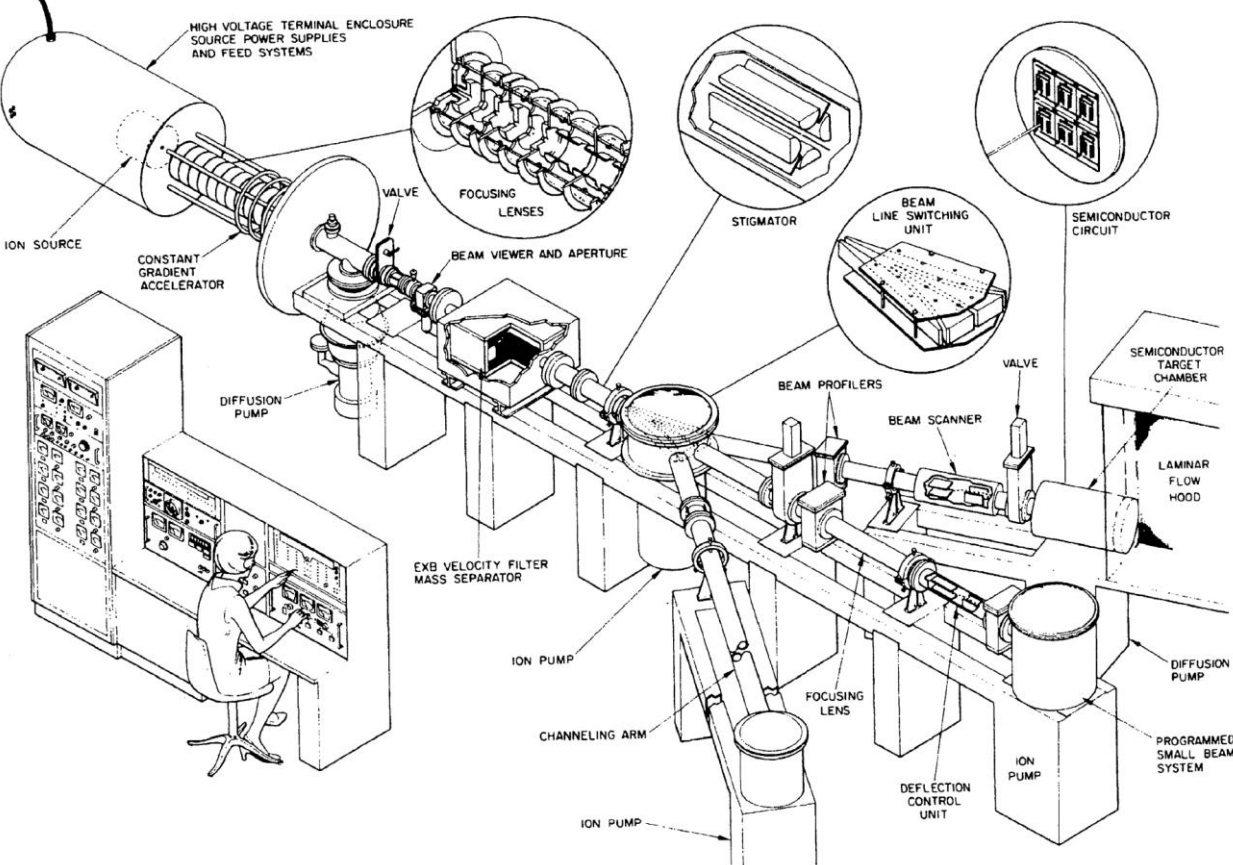

Figure 5: Drawing of a 300-kV ion-implantation system [1].

ION-EXCHANGE FABRICATION PROCEDURE

- The process involves ion-exchange between the salt and glass which increases the refractive index.
- The substrate layer of a diffused-channel waveguide is made of materials such as soda lime glass, Pyrex, Corning 3-71, or borosilicate (BK7).
- A mask is placed on the substrate and the substrate is baked with the salt.
- The main advantage of an ion-exchange waveguide is its low propagation losses, although its structure is optically weak ($\Delta = 0.5\%$ in BK7, using KNO_3).

ION-EXCHANGE FABRICATION PROCEDURE

- Conventional photolithography
 - SM
 - < 8dB coupling efficiency;
- 0.2 dB/cm prop. loss

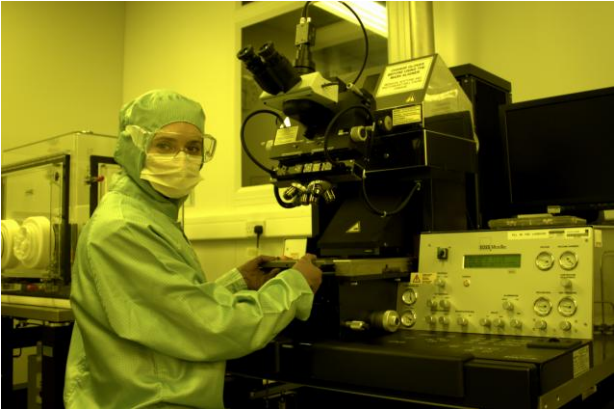

1. Cleaning



2. Al mask e-beam deposition



3. Positive photolithography

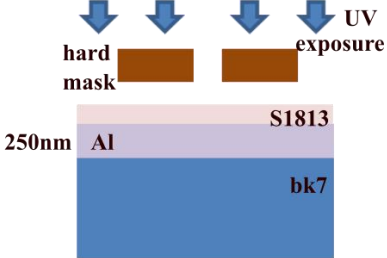

4. Resist removal

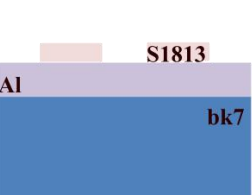

5. Al etch



6. Immersion in KNO_3 @395C for 11hr

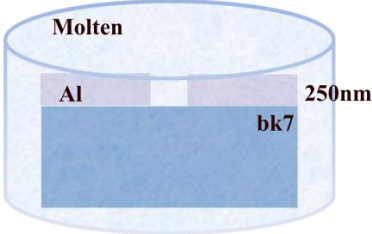

6. Sawing/Lapping/Polishing



5mm from each side



lapping/polishing jig

holding jig



SPATIAL DISTRIBUTION OF REFRACTIVE INDEX

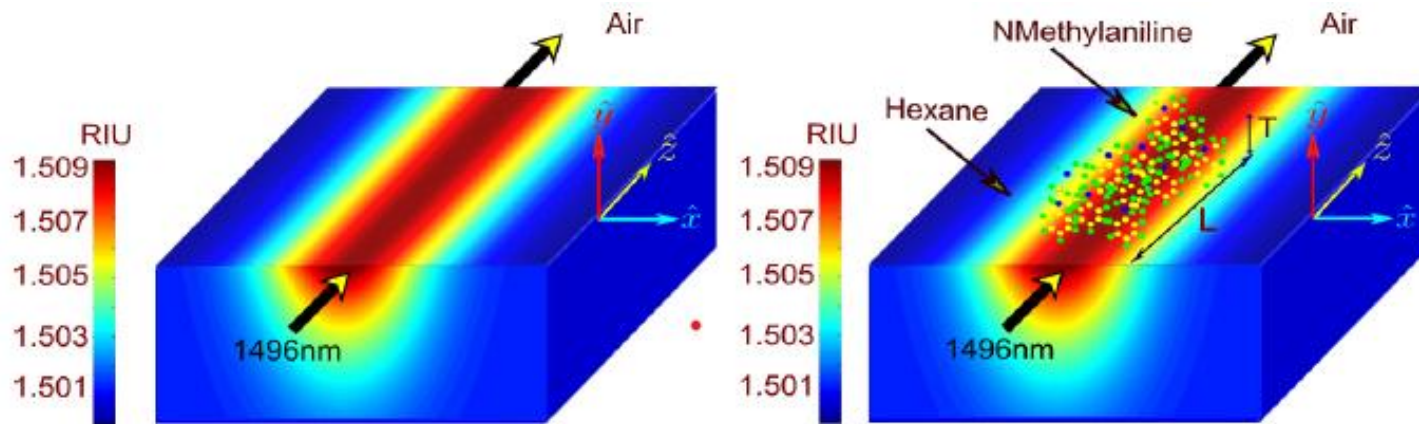

$$n(x, y) = n_s + \Delta n \cdot \operatorname{erfc}\left(\frac{y}{dy}\right) \exp\left(\frac{-x^2}{dx^2}\right)$$

$$n_s = 1.50127$$

Δn increases in refractive index at the surface

$$\Delta n_{TM} = 0.0092 \text{ and } \Delta n_{TE} = 0.008$$

dy - refractive index profile depth

dx - refractive index profile half-width

ION EXCHANGE OPTICAL WAVEGUIDES

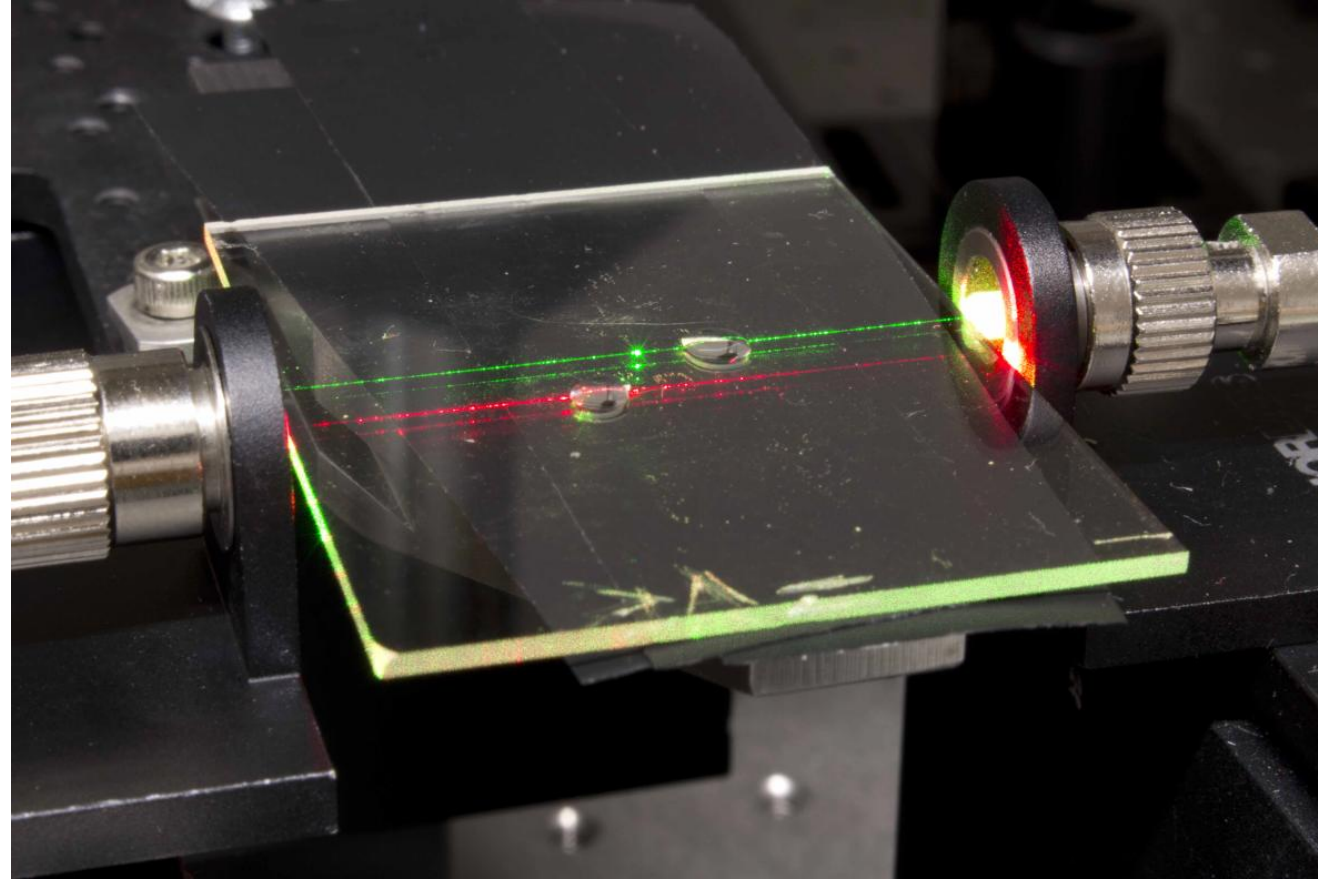



LASER-WRITTEN WAVEGUIDES

LASER-WRITTEN WAVEGUIDES

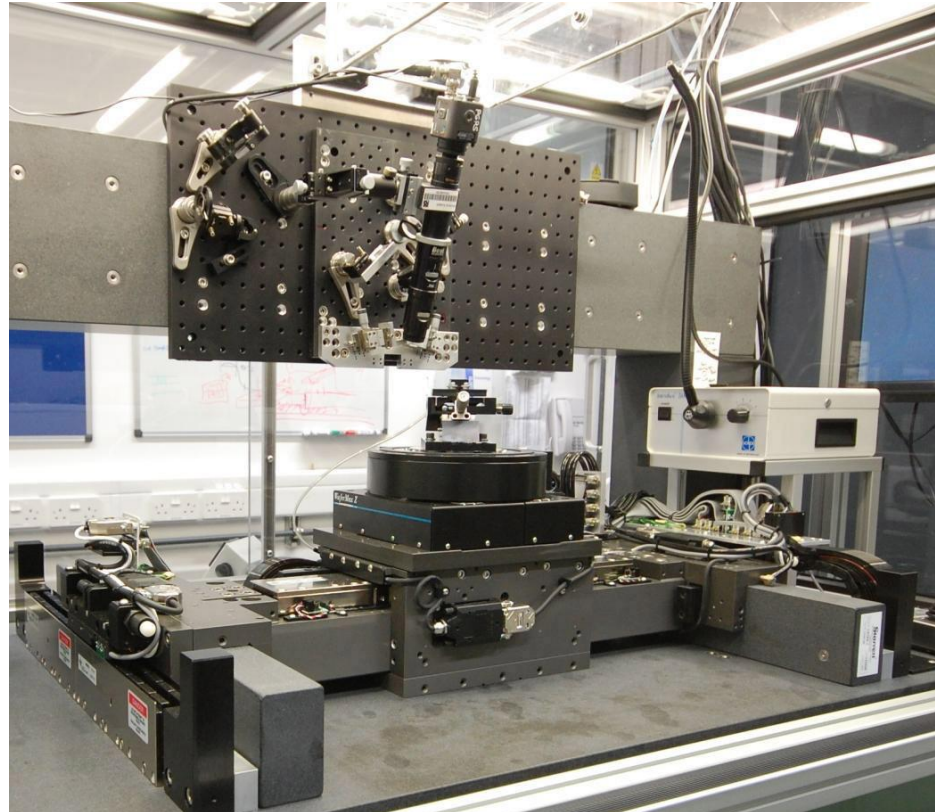
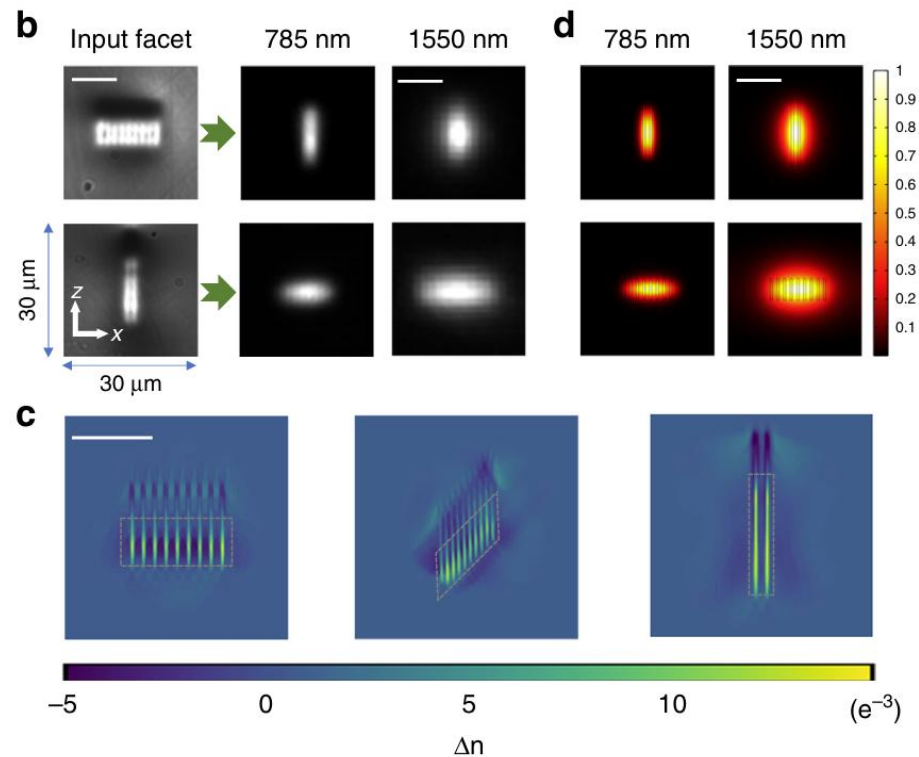
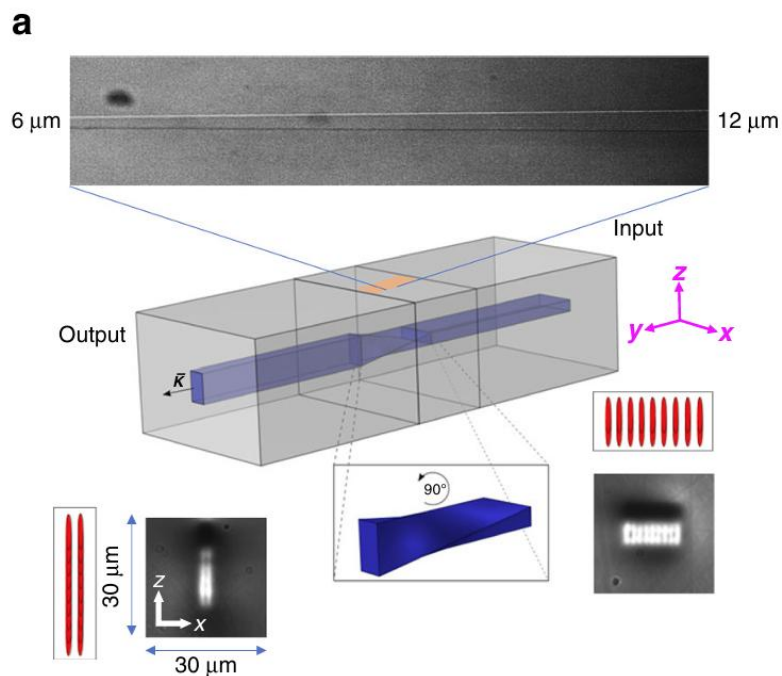

Figure 6: Set-up of UV written waveguides, Peter Smith lab, ORC, UoS.



LASER-WRITTEN WAVEGUIDES

Sun, B., Morozko, F., Salter, P. S., Moser, S., Pong, Z., Patel, R. B., Walmsley, I. A., Wang, M., Hazan, A., Barré, N., Jesacher, A., Fells, J., He, C., Katiyi, A., Tian, Z. H., Karabchevsky, A. and Booth, M. J., 'On-chip beam rotators, adiabatic mode converters, and waveplates through low-loss waveguides with variable cross-sections'. *Light: Science & Applications*, 11(1), 1-15 (2022).

LASER-WRITTEN WAVEGUIDES

- CW or pulsed light from a laser used for writing waveguides in silica and other glasses.
- Photosensitivity of germanium-doped silica exploited to enhance refractive index in the region exposed to a UV laser.
- Absorption of 244 nm light from a krypton fluoride (KrF) laser changes the refractive index by $\sim 10^{-4}$ only in the region exposed to UV light.
- Index changes $> 10^{-3}$ can be realized with a 193-nm Argon fluoride (ArF) laser. This laser is used also in eye surgery and micro-machining.
- A planar waveguide is formed first through CVD, but the core layer is doped with germania.
- A UV beam focused to ~ 1 mm is scanned slowly to enhance n selectively. UV-written sample is then annealed at 80C.

LASER-WRITTEN WAVEGUIDES

- Femtosecond pulses from a Ti:sapphire laser can be used to write waveguides in bulk glasses.
- Intense pulses modify the structure of silica through multiphoton absorption.
- Refractive-index changes $\sim 10^{-2}$ are possible.

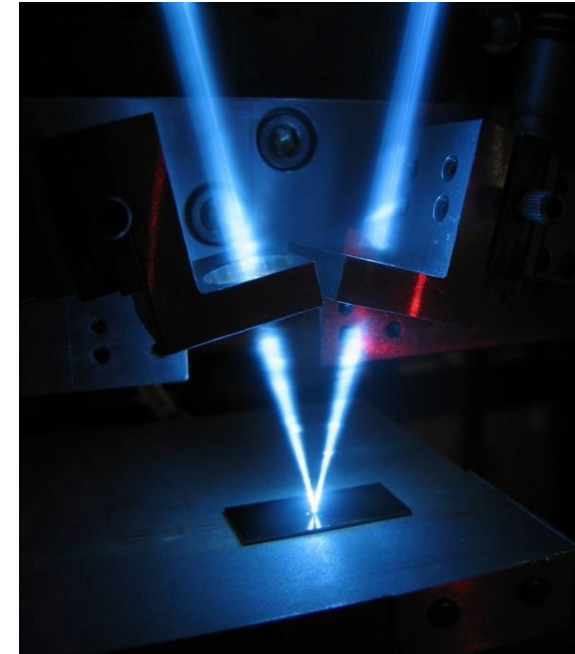

Figure 7: UV written waveguides from Peter Smith lab, ORC, UoS.



- 1) Explain the mechanism of annealing.
- 2) Explain the mechanism of RIE (reactive ion etching).

BIBLIOGRAPHY

[1] Hunsperger, R. G. (1995). Integrated optics (Vol. 4). Berlin, Heidelberg: Springer Verlag.

[2] Kuhn, L., et al. "Deflection of an optical guided wave by a surface acoustic wave." *Applied Physics Letters* 17.6 (1970): 265-267..

[3] Hiraki, Tatsurou, et al. "Heterogeneously integrated iii–v/si mos capacitor mach–zehnder modulator." *Nature Photonics* 11.8 (2017): 482-485.